

2024

SPL Life Sciences
Products Catalogue



Breakthroughs for a better life

www.ispl.co.kr

CE ISO 9001 ISO 13485

 **SPL**
SPL LIFE SCIENCES

2024 Products Catalogue

Global standard core-technology of SPL Life Sciences is trusted by experts who have been dedicated to humanity and they are striving for a better life and transforming human life through advanced products of SPL Life Sciences.

Pride

As a leading manufacturer / exporter of laboratory plasticware in Korea, SPL Life Sciences Co., Ltd. has been dedicated to manufacturing high qualified products compliant with finest standards in the scientific field since established in 1987. The company is so proud that it has since known to be a supplier/manufacturer of products meeting requirements for international regulations completely, and with enthusiastic experts who have been putting their efforts into R&D, quality maintenance consistently.

State of The Art Products

A very rich expertise and experience obtained for over the last 3 decades in the field enable our qualified professionals to deliver finest quality products to the customers at the competitive prices. Not only in Korean domestic market, also in global market such as USA, EU, and most of Asian countries, we've got crowning achievement in global business and have made a name for ourselves globally as the leader who quickly and regularly develops and shows off state of the art products applicable to life sciences.

Innovative Solutions

SPL Life Sciences, a company doing level best to meet the customers' needs for up to dated life sciences technology, is committed to providing the innovative solutions in wide range of its filed through aggressive investment for R&D.

spllifesciences.com

SPL Lifesciences Headquarters

R&D Center, A Plant, B Plant, C Plant

48, Geumgang-ro 2047beon-gil, Naecheon-myeon, Pocheon-si, Gyeonggi-do, Korea

Naejin-ro Plant I - E Plant, P Plant

266, Naejin-ro, Naecheon-myeon, Pocheon-si, Gyeonggi-do, Korea

Naejin-ro Plant II - F Plant, K Plant

310-16, Naejin-ro, Naecheon-myeon, Pocheon-si, Gyeonggi-do, Korea

General Product Inquiries

TEL. +82 31)533-4800

business@ispl.co.kr



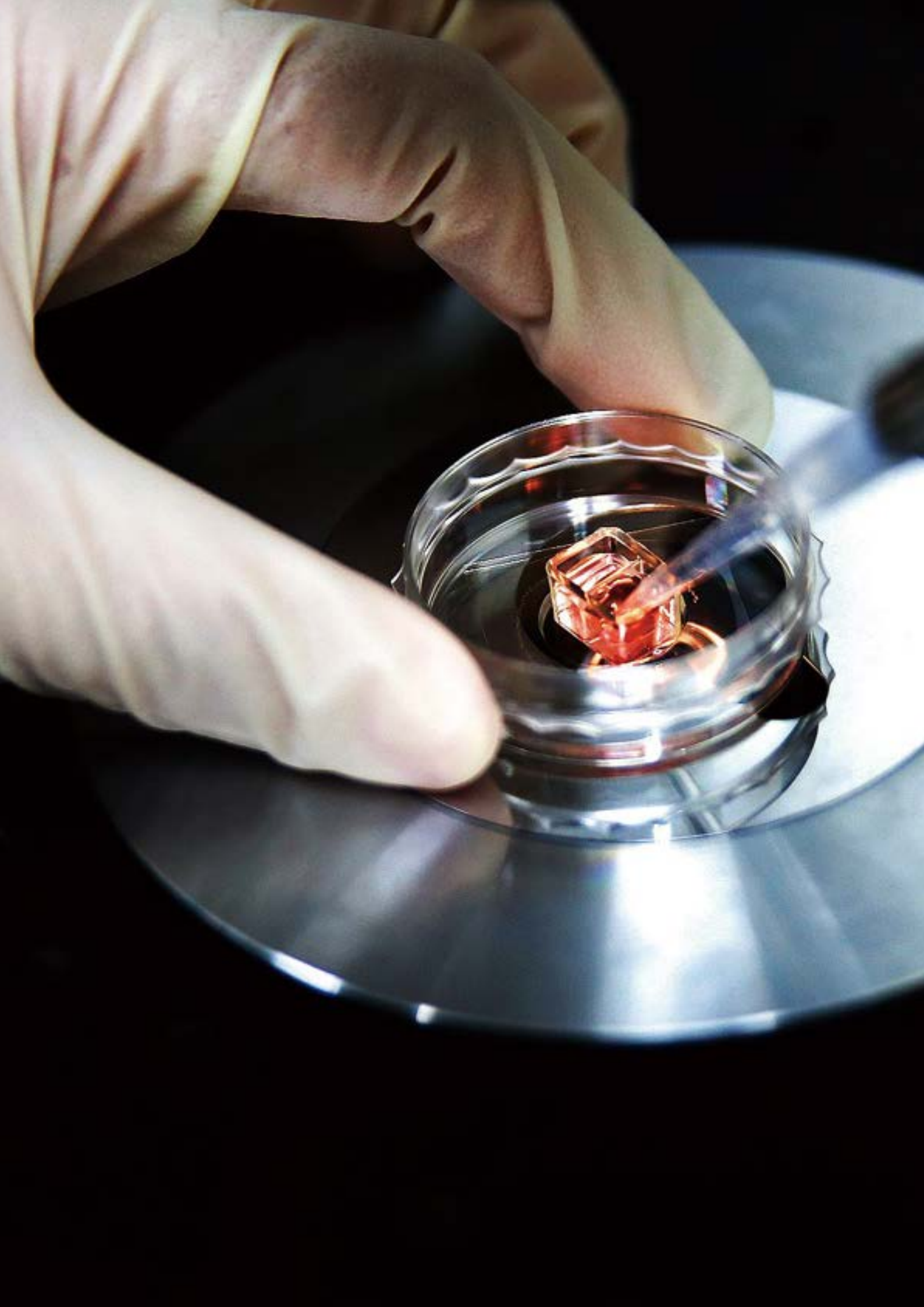



Sterility

The sterility of SPL products is fully validated and qualified to be in compliance with ISO 11137-1 regulatory requirements that includes the routine control of sterilization process. Randomized selection, examination and monitoring ensures the overall process and products, labeled as sterile, are within the predetermined limits with an SAL (Sterility Assurance Level) of 10^{-6} .

Non-cytotoxic

The cytotoxicity of SPL products is routinely tested according to the principles of the MEM Elution, described by the ISO guidelines.

Non-pyrogenic

Endotoxin level of SPL products are tested according to the principles of the LAL (Limulus Amoebocyte Lysate) test, described in the FDA guidelines for medical products, and certified to be non-pyrogenic with a documented endotoxin level of less than 0.01 EU / ml.

DNase / RNase-free

SPL products are routinely tested according to the Standard Operating Procedure of SPL Life Sciences, and certified to be less than 1×10^{-6} Kunitz units for DNase, 1×10^{-9} Kunitz units for RNase.

Human DNA-free

The human DNA of SPL products are routinely tested according to the Standard Operating Procedure of SPL Life Sciences, and certified to be less than 2 pg for human DNA.

**Want to learn more
about products of
SPL Life Sciences used in
specialized bioprocess?**

**SPL Life Sciences
provides customized
bioprocessing services
to help you get the
answers you need.**

**We are ready to fulfill
your unique needs.**

Contents

	Highlights 2024	8
01	Cell Culture	14
	1-1 Cell Cultureware	18
	1-2 SPLCoat™	30
	1-3 Cellular Imaging	38
	1-4 SPL3D™	48
	1-5 SPLInsert™	54
	1-6 SPLPermea™	60
	1-7 SPLScar™	62
	1-8 <i>In vitro</i> Fertilization	64
	1-9 Cryopreservation	66
	1-10 SPLFlow™	70
	1-11 Accessories	72
02	Molecular Analysis	76
	2-1 Immunoassay	78
	2-2 Molecular Biology	84
	2-3 SPLPro-Crystal™	94
	2-4 Accessories	96
03	Microbiology	98
	3-1 Dishes & Vessels	100
	3-2 Accessories	106
04	Handling & Storage	108
	4-1 Liquid Handling	110
	4-2 Tubes	116
	4-3 Racks & Boxes	130
	4-4 Bottles	136
	4-5 Storage & Accessories	146
05	Plant & Insect Culture	158
	5-1 Plant Culture	160
	5-2 Insect Culture	165
06	Clinical Labware	168
	6-1 Clinical Labware	170
	Appendix	
	Product Raw material Chemical Resistance Chart	179
	Alphabetical Index	180
	Numerical Index	182

Highlights 2024

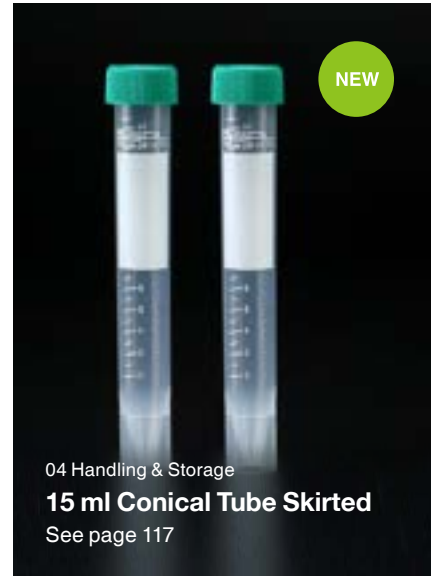

04 Handling & Storage
5 ml Screw / Snap Tube See page 120 / 121

04 Handling & Storage
2 ml Reinforced Tube See page 125



04 Handling & Storage
Septum Tube See page 122



01 Cell Culture
Strainer Tube See page 75

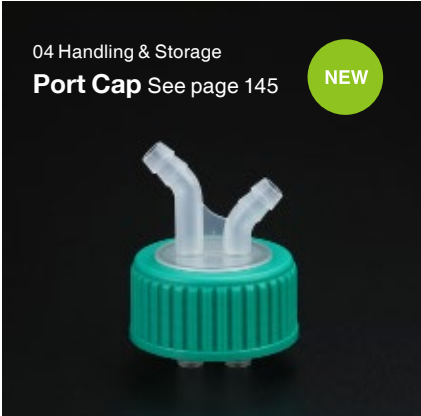

02 Molecular Analysis
Vacuum Filter Tube See page 87

02 Handling & Storage
Storage Bottle See page 144

02 Molecular Analysis
Bottle Top Filter Unit See page 93



04 Handling & Storage
Biotainer See page 144



02 Molecular Analysis
Cuvette See page 90

Highlights 2024



02 Molecular Analysis
qPCR Tube 8-Strip White See page 84



02 Handling & Storage
Serological Pipette Pla / Pla See page 110

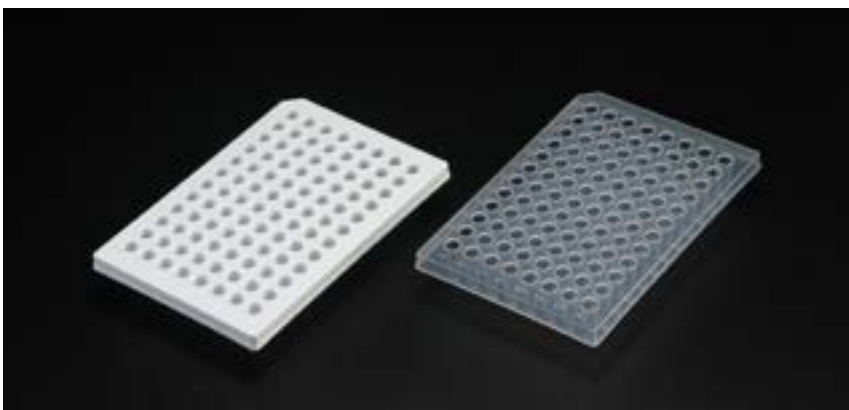

02 Molecular Analysis
PCR Plate See page 85



02 Molecular Analysis
SPL SEAL™ See page 96



01 Cell Culture
Spheroid Forming Unit See page 50



02 Molecular Analysis
Dialysis Chamber See page 88

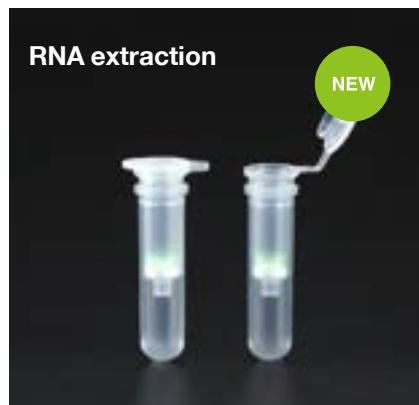

02 Molecular Analysis
Spin Column See page 93

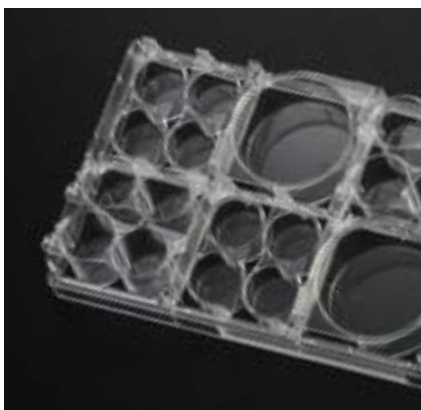

01 Cell Culture
Module Plate See page 29



01 Cell Culture
Black Plate, White Plate See page 39, 40



04 Handling & Storage
V-Type Storage Plate 96well See page 149



04 Handling & Storage
Deep Well Plate See page 146

Highlights 2024



01 Cell Culture
Cell Floater See page 48



01 Cell Culture
Spheroid Dish See page 50



01 Cell Culture
Multi Insert Dish See page 52



01 Cell Culture
SPLInsert™ Hanging See page 56



01 Cell Culture
SPLInsert™ Standing See page 58

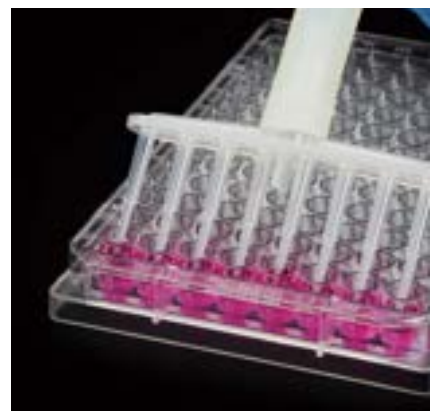

04 Handling & Storage
Q-suction 8-Tip See page 114

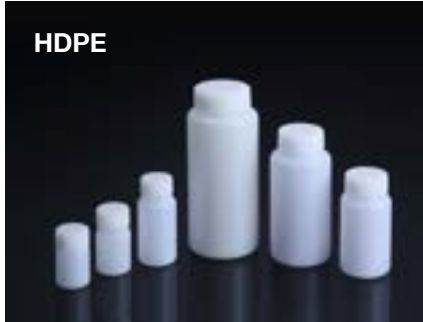

04 Handling & Storage
Wide Mouth Bottle See page 137~139



04 Handling & Storage
60 ml Media Bottle See page 140



04 Handling & Storage
Media Bottle See page 140

Cell Culture

For more than a century, cells have provided humanity with deep and fascinating insights into nature. Being a common laboratory technique, cell culture is one of the most critical aspects in biology-related researches and industries.

SPL provides customers with a wide range of high quality cell culture products, including cell culture flasks, cell culture dishes, microplates, cryovials, and other essential accessories.

All SPL products meet the international guidelines including ISO 9001 and USP class VI compliance.

1-1. Cell Cultureware 18

Cell Culture Flask.....	19
Cell Culture Dish.....	21
Cell Culture Plate.....	22
Miniwell Tray.....	24
Black & White Plate 96well.....	24
Square Dish.....	25
Tray Plate.....	25
Roller Bottle.....	26
Erlenmeyer Flask.....	27
Cell Culture Square Bottle.....	28
Bioreactor.....	29
Cell Culture Module Plate.....	29

1-2. SPLCoat™ 30

SPLCoat™ Collagen Type I Coated Ware.....	32
SPLCoat™ Poly-D-Lysine Coated Ware.....	33
SPLCoat™ Laminin Coated Ware.....	34
SPLCoat™ Collagen Type IV Coated Ware...	35
SPLCoat™ Fibronectin Coated Ware.....	36
SPLCoat™ Matrix™ Coated Ware.....	37

1-3. Cellular Imaging 38

Black Plate.....	39
White Plate.....	40
Coverslip.....	41
Microscopy Coverslip.....	41
Cell Culture Slide I.....	42
Cell Culture Slide II.....	44
Co Culture Slide.....	45
Cell Culture Slide Hybridwell™.....	46
Confocal Dish & Plate.....	46

1-4. SPL3D™ 48

Cell Floater.....	48
Spheroid Forming Unit.....	50
Spheroid Dish.....	50
Spheroid Forming Gel.....	51
96well Hanging Drop Plate.....	52
Multi Insert Dish.....	52

1-5. SPLInsert™	54	1-9. Cryopreservation	66
Co-culture Dish (JLK).....	55	Cryovial.....	66
SPLInsert™ Hanging	56	Cryo Tissue Container	67
SPLInsert™ Standing	58	Cryo Box	68
		Cryovial Rack.....	69
1-6. SPLPermea™	60	1-10. SPLFlow™	70
SPLPermea™ Dish.....	60	SPLFlow™	70
SPLPermea™ Bag	60		
SPLPermea™ Rack	61	1-11. Accessories	72
1-7. SPLScar™	62	Cell Strainer	72
SPLScar™ Scratcher.....	62	Multi C-Strainer.....	73
SPLScar™ Block.....	63	Cell Lifter.....	74
		Cell Scraper	74
1-8. <i>In vitro</i> Fertilization	64	Strainer Tube	75
Cell Culture Plate 4well.....	65	Cloning Cylinder	75
IVF Dish.....	65		

Cell Culture

For more than a century, cell culture researches have provided humanity with deep and fascinating insights into nature. Being a common laboratory technique, cell culture is one of the most critical aspects in biology-related researches and industries.

SPL Life Sciences provides customers with a wide range of high quality cell culture products, from basic cell culture vessels to more advanced platforms and accessories.

All SPL cell culture products meet international guidelines and regulations, such as ISO (International Organization for Standardization), ANSI (American National Standard Institute), and USP (United States Pharmacopeia, class VI). Polymer resins used to manufacture all products have followed international guidelines such as CONEG, SARA, Reach EC / 1907 / 2006, RoHS 2015 / 863 / EU. Biological tests (endotoxin, cytotoxicity, DNase / RNase / Human DNA) as well as cell attachment tests are regularly performed for quality control.



	Surface			Materials								
	Cell Culture-Treated	Non-Treated	SPLCoat™	PS	Glass	DLux	FLux	SPLPermea™	PC	PET	PP	Nylon
Cell Culture Ware	•	•	•	•							•	
SPLCoat™			•	•	•							
Cellular Imaging	•	•	•	•	•	•	•					
SPL3D™	•	•										
SPLInsert™	•	•		•					•	•	•	
SPLPermea™		•						•				
SPLScar™						N/A						
<i>in vitro</i> Fertilization	•	•		•				•				
Cryoware						N/A						
SPLFlow™							•					
Accessories						N/A						

Surfaces & Materials of SPL Life Sciences Cell Culture Products

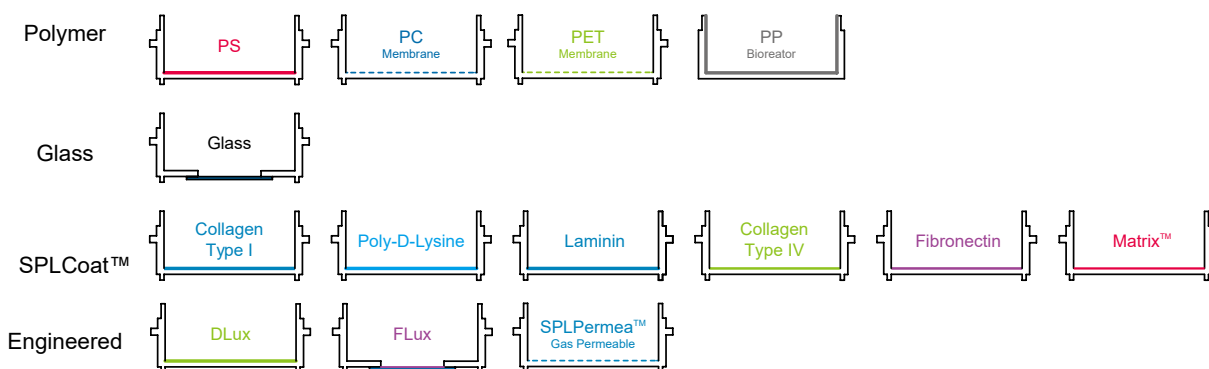

Surfaces

SPL Life Sciences offers a great diversity in surface conditions suitable for optimal cell growth. The suitability and efficiency of such treatments are routinely confirmed.

Cell Culture-Treated	Optimal surface that facilitates cell attachment and growth, perfectly got most applications involving adherent cell culture.
Non-Treated	Naturally charged and relatively hydrophobic compared to treated surface, better for suspension cell culture.
SPLCoat™	Uniform coatings of ECM proteins/chemicals that enhance cell attachment, growth and differentiation.

Materials

Polymer	Polystyrene (PS)	Made of optically clear and transparent polystyrene suitable for observation. Polystyrene is especially useful material option in cell culturewares since it promote cell attachment, and is applicable to all surface treatments.
	Polycarbonate (PC)	Provided in porous membrane that is stain-free, low background interference.
	Polyethylene terephthalate (PET)	Provided in porous membrane that retain high chemical resistance and low protein binding property.
	Polypropylene (PP)	Biocompatible polymer for suspension culture.
Engineered	DLux	Surface modified plastic for enhanced cell attachment, with minimal autofluorescence and high chemical resistance.
	FLux	Surface modified plastic film for enhanced cell attachment, optimal for confocal microscopy.
	SPLPermea™	Engineered gas-permeable film that allows rapid equilibration between partial pressures of oxygen in the atmosphere and the ware.
	Glass	Naturally charged and relatively hydrophobic compared to treated surface.

Cell Culture

1-1. Cell Culturewares

SPL Cell Culturewares are ergonomically designed to maximize safety, efficiency and convenience in cell culture experiments, to meet the demands of all users.

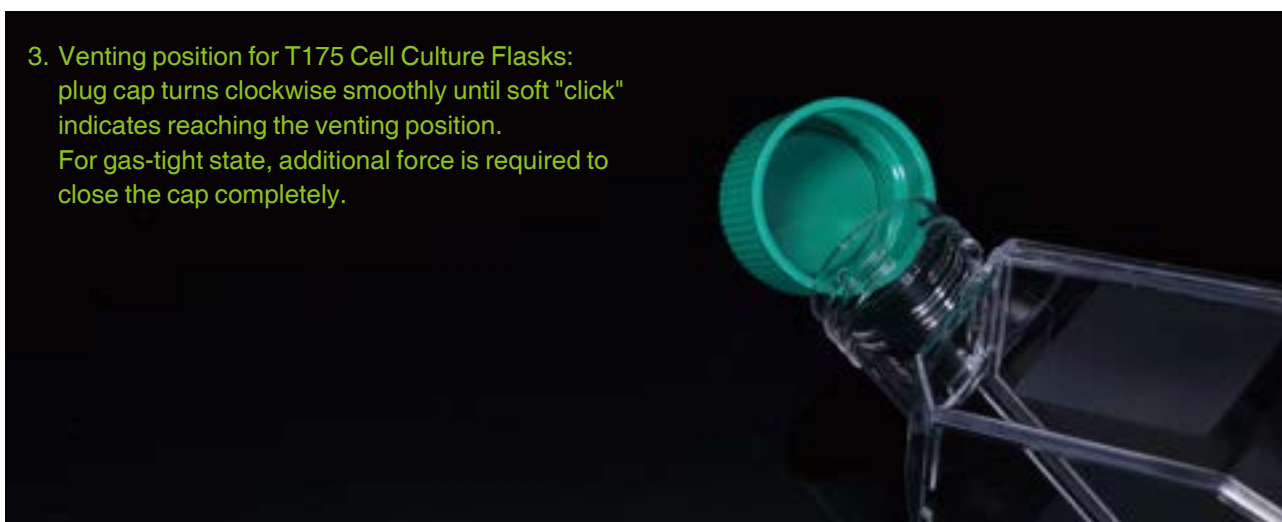
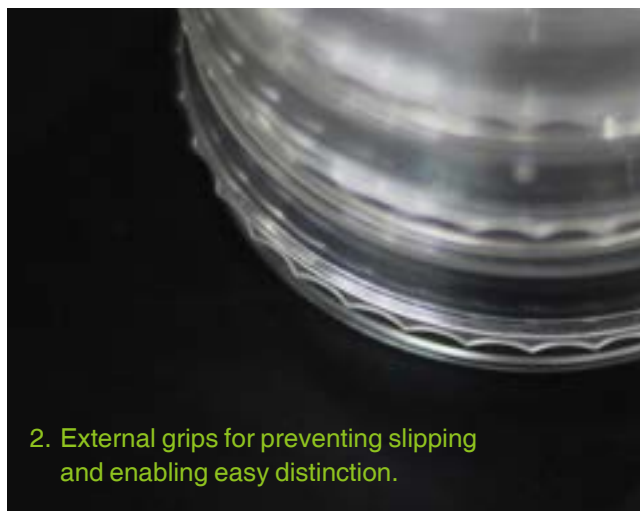

	Surface			Materials				
	Cell Culture-Treated	Non-Treated	SPLCoat™	PS	PP	PC	PET	HDPE
Cell Culture Flask	•	•	•	•				•
Cell Culture Dish	•	•	•	•				
Cell Culture Plate	•	•	•	•				
Square Dish	•			•				
Tray Plate	•			•				
Roller Bottle	•	•		•				•
Erlenmeyer Flask		•			•	•		
Square Bottle		•					•	•
Bioreactor		•			•			•

Cell Culture Flask

Cell Culture Flasks of SPL Life Sciences are ergonomically designed for easy handling, while achieving minimal contamination during cell culture. Short, wide and angled neck design enables easy access of serological pipettes and cell scrapers. Flasks are divided into 20 types, depending on the culture scale, the cap type and surface treatment cell growth area for T12.5, T25, T75, T175 and T225 are 12.5 cm², 25 cm², 75 cm², 175 cm² and 225 cm², respectively. Each flask can be provided with plug or filter caps.

- Ergonomic design to facilitate easy handling and minimize contamination
- Short & wide neck with angled design allows easy access
- Excellent stackability
- Plugs & filter caps are available for all flask models
- Cell growth area ranging from 12.5 cm², 25 cm², 75 cm², 175 cm² and 225 cm²
- Venting position for 175 cm², 225 cm² plug cap model (Cat. No. 72175, 73175, 701225)
- Non-treated models (for suspension culture) are provided with the white caps
- Non-pyrogenic
- Non-cytotoxic
- DNase / RNase-free
- Human DNA-free



continued on next page

Cell Culture



Cell Culture Flask

Type	Cat. No.	Material (Body / Cap)	Cap Type	Growth Area (cm ²)	Working Vol. (ml)	Total Vol. (ml)	Surface Treatment	Sterile	Packaging	
Cell Culture Flask 12.5 cm²										
		70012	PS / HDPE	Filter	12.50	5.00	25.00	+	+	5 / 200
		70112	PS / HDPE	Plug	12.50	5.00	25.00	+	+	5 / 200
		70312	PS / HDPE	Filter	12.50	14.00	25.00	-	+	5 / 200
		70212	PS / HDPE	Plug	12.50	14.00	25.00	-	+	5 / 200
Cell Culture Flask 25 cm²										
		70025	PS / HDPE	Filter	25.00	7.00	60.00	+	+	5 / 200
		70125	PS / HDPE	Plug	25.00	7.00	60.00	+	+	5 / 200
		70325	PS / HDPE	Filter	25.00	40.00	60.00	-	+	5 / 200
		70225	PS / HDPE	Plug	25.00	40.00	60.00	-	+	5 / 200
Cell Culture Flask 75 cm²										
		70075	PS / HDPE	Filter	75.00	25.00	250.00	+	+	5 / 100
		70175	PS / HDPE	Plug	75.00	25.00	250.00	+	+	5 / 100
		70375	PS / HDPE	Filter	75.00	170.00	250.00	-	+	5 / 100
		70275	PS / HDPE	Plug	75.00	170.00	250.00	-	+	5 / 100
Cell Culture Flask 175 cm²										
		71175	PS / HDPE	Filter	175.00	50.00	650.00	+	+	5 / 40
		72175	PS / HDPE	Plug	175.00	50.00	650.00	+	+	5 / 40
		74175	PS / HDPE	Filter	175.00	450.00	650.00	-	+	5 / 40
		73175	PS / HDPE	Plug	175.00	450.00	650.00	-	+	5 / 40
Cell Culture Flask 225 cm²										
		700225	PS / HDPE	Filter	225.00	60.00	850.00	+	+	5 / 25
		701225	PS / HDPE	Plug	225.00	60.00	850.00	+	+	5 / 25
		703225	PS / HDPE	Filter	225.00	600.00	850.00	-	+	5 / 25
		702225	PS / HDPE	Plug	225.00	600.00	850.00	-	+	5 / 25

For surface coated Cell Culture Flasks (SPLCoat™- Collagen type I & IV, Poly-D-Lysine, Laminin, Fibronectin, Matrix™) see page 30 - 37

Cell Culture Dish

SPL Life Sciences provides a wide range of Cell Culture Dishes with the highest quality. All of the Cell Culture Dishes are produced with optically clear, high quality polymers for microscopy.

- Unique lid inner design for effective gas exchange
- External grip for better handling (Cat. No. 11035, 11060, 20035, 20060, 20101)
- Excellent stackability
- Compliant with USP guideline (USP class VI tested)
- Non-pyrogenic
- Non-cytotoxic
- DNase / RNase-free
- Human DNA-free



Cell Culture Dish

Type	Cat. No.	Dish Style d x h (mm)	Internal Dimensions d x h (mm)	Growth Area (cm ²)	Working Vol. (ml)	External Grip	Surface Treatment	Sterile	Packaging
○	11035	35.00 x 10.00	35.00 x 9.60	9.40	3.00	+	-	+	10 / 500
○	11060	60.00 x 15.00	52.80 x 12.80	21.50	5.00	+	-	+	10 / 500
○	11090	90.00 x 15.00	85.73 x 12.60	57.50	12.50	-	-	+	10 / 500
○	11150	150.00 x 20.00	138.57 x 15.40	148.00	35.00	-	-	+	10 / 120
○	11151	150.00 x 25.00	138.57 x 23.30	148.00	35.00	-	-	+	10 / 120
○	20035	35.00 x 10.00	35.00 x 9.60	9.40	3.00	+	+	+	10 / 500
○	20060	60.00 x 15.00	52.80 x 12.80	21.50	5.00	+	+	+	10 / 500
○	20100	90.00 x 20.00	86.26 x 17.70	57.50	12.50	-	+	+	10 / 200
○	20101	90.00 x 20.00	87.48 x 16.40	57.50	12.50	+	+	+	10 / 200
○	20150	150.00 x 25.00	138.57 x 23.30	148.00	35.00	-	+	+	10 / 120
○	20151	150.00 x 20.00	138.57 x 15.40	148.00	35.00	-	+	+	10 / 120

For surface coated Cell Culture Dishes (SPLCoat™ - Collagen type I & IV, Poly-D-Lysine, Laminin, Fibronectin, Matrix™) see page 30 - 37

Cell Culture

Cell Culture Plate





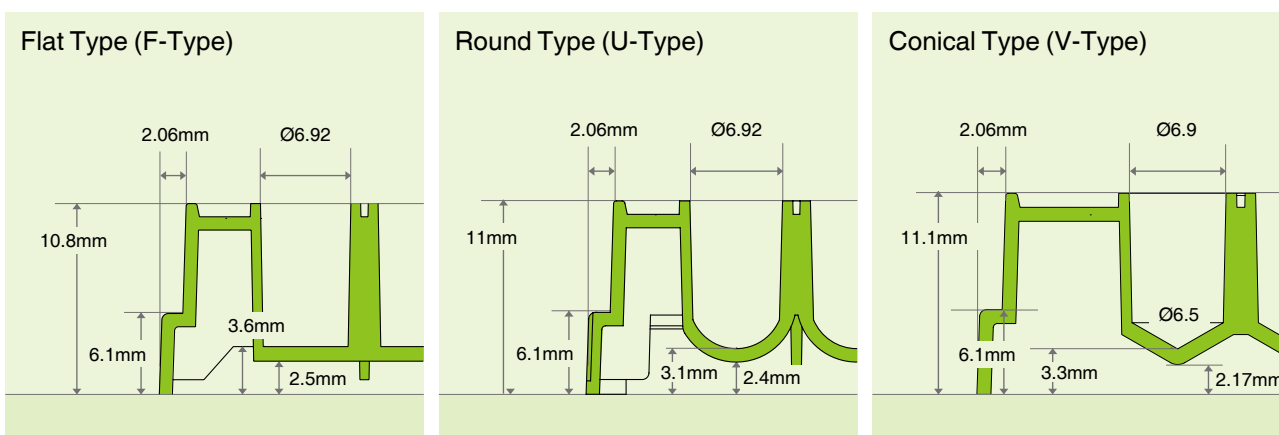

Cell Culture Plates are widely used for handling multiple samples in a single experiment during cell culture. SPL Life Sciences provides a wide range of multiwell plates from 6well to 384well plates for cell culture purposes.

- Designed to prevent cross contamination
- Effective gas exchange lid inner design
- Alphanumeric labeling
- Homogeneous cell culture
- 3 bottom types for 96well plates: Flat / Round / Conical
- HTS (High-Throughput Screening) compatible for 96well and 384well plates
- Compliant with USP guideline (USP class VI tested)
- Compliant with ANSI guideline
- Non-pyrogenic
- Non-cytotoxic
- DNase / RNase-free
- Human DNA-free



continued on next page

**Cell Culture Plate**

Type	Cat. No.	Material	External Dimensions w x l x h (mm)	Bottom Type	Well Dimensions d x h (mm)	Growth Area (cm ²)	Working Vol. (ml)	Surface Treatment	Sterile	Packaging
Cell Culture Plate 6well										
	30006	PS	85.40 x 127.60 x 20.20	Flat	35.00 x 17.50	9.60	3.00	+	+	1 / 50
	31006	PS	85.40 x 127.60 x 20.20	Flat	35.00 x 17.50	9.60	3.00	-	-	1 / 50
	32006	PS	85.40 x 127.60 x 20.20	Flat	35.00 x 17.50	9.60	3.00	-	+	1 / 50
Cell Culture Plate 12well										
	30012	PS	85.40 x 127.60 x 20.20	Flat	21.90 x 17.50	3.80	2.00	+	+	1 / 50
	31012	PS	85.40 x 127.60 x 20.20	Flat	21.90 x 17.50	3.80	2.00	-	-	1 / 50
	32012	PS	85.40 x 127.60 x 20.20	Flat	21.90 x 17.50	3.80	2.00	-	+	1 / 50
Cell Culture Plate 24well										
	30024	PS	85.40 x 127.60 x 20.20	Flat	15.50 x 17.50	1.90	1.00	+	+	1 / 50
	31024	PS	85.40 x 127.60 x 20.20	Flat	15.50 x 17.50	1.90	1.00	-	-	1 / 50
	32024	PS	85.40 x 127.60 x 20.20	Flat	15.50 x 17.50	1.90	1.00	-	+	1 / 50
Cell Culture Plate 48well										
	30048	PS	85.40 x 127.60 x 20.20	Flat	9.75 x 17.50	0.75	0.50	+	+	1 / 50
	31048	PS	85.40 x 127.60 x 20.20	Flat	9.75 x 17.50	0.75	0.50	-	-	1 / 50
	32048	PS	85.40 x 127.60 x 20.20	Flat	9.75 x 17.50	0.75	0.50	-	+	1 / 50
Cell Culture Plate 96well										
	30096	PS	85.40 x 127.60 x 14.40	Flat	6.50 x 10.80	0.33	0.20	+	+	1 / 50
	31096	PS	85.40 x 127.60 x 14.40	Flat	6.50 x 10.80	0.33	0.20	-	-	10 / 100
	32096	PS	85.40 x 127.60 x 14.40	Flat	6.50 x 10.80	0.33	0.20	-	+	1 / 50
	34096	PS	85.40 x 127.60 x 14.40	Round	6.92 x 11.00	0.66	0.20	+	+	1 / 50
	34196	PS	85.40 x 127.60 x 14.40	Round	6.92 x 11.00	0.66	0.20	-	-	10 / 100
	34296	PS	85.40 x 127.60 x 14.40	Round	6.92 x 11.00	0.66	0.20	-	+	1 / 50
	36196	PS	85.40 x 127.60 x 14.40	Conical	6.92 x 11.00	0.38	0.20	-	-	10 / 100
	36296	PS	85.40 x 127.60 x 14.40	Conical	6.92 x 11.00	0.38	0.20	-	+	1 / 50
Cell Culture Plate 384well										
	37384	PS	85.40 x 127.60 x 14.40	Flat	3.00 x 11.50	0.07	0.10	+	+	10 / 40
	38384	PS	85.40 x 127.60 x 14.40	Flat	3.00 x 11.50	0.07	0.10	-	+	10 / 40

For surface coated Cell Culture Plates (SPLCoat™ - Collagen type I & IV, Poly-D-Lysine, Laminin, Fibronectin, Matrix™) see page 30 - 37p

Cell Culture



Miniwell Tray

Miniwell Trays are used in a broad spectrum of applications, including cloning experiments, sample incubation, and tissue culture based analytical systems. The crystallization drop is localized centrally as a result of the conical well geometry, and the flat bottom makes for optimal monitoring.

- Terasaki format plate
- Stackable
- Used in serotyping, micro-cytotoxicity and cell cloning studies
- Virgin, high clarity polystyrene (Excellent optical)
- Surface treatment and Sterilized (Cat. No. 30060, 30072)
- Non-pyrogenic
- Non-cytotoxic
- DNase / RNase-free
- Human DNA-free



Miniwell Tray

Type	Cat. No.	Well Type	Material	External Dimension w x l (mm)	Working vol. (µl)	Surface Treatment	Sterile	Packaging
	30060	60	PS	83.00 x 58.00	10.00	+	+	10 / 100
	31060	60	PS	83.00 x 58.00	10.00	-	-	10 / 100
	30072	72	PS	83.00 x 58.00	10.00	+	+	10 / 100
	31072	72	PS	83.00 x 58.00	10.00	-	-	10 / 100

Black & White Plate 96well





Black Plates are designed for minimum light scattering and cross-talk during fluorescence assay. White Plates provide maximum reflection and minimum cross-talk for luminescence assay.

- HTS (High-Throughput Screening) compatible
- Suitable for fluorescence and luminescence assay
- Non-treated for suspension culture (Cat. No. 30396, 30496)
- Designed to prevent cross contamination
- Effective gas exchange lid inner design
- Alphanumeric labeling
- Homogeneous cell culture
- Flat bottom
- Compliant with USP guideline (USP class VI tested)
- Compliant with ANSI guideline
- Non-pyrogenic
- Non-cytotoxic
- DNase / RNase-free
- Human DNA-free



continued on next page

Black & White Plate 96well

Type	Cat. No.	Material	Color	External Dimensions w x l x h (mm)	Well Dimensions d x h (mm)	Growth Area (cm ²)	Working Vol. (ml)	Surface Treatment	Sterile	Packaging
	30196	PS	White	85.40 x 127.60 x 14.40	6.50 x 10.80	0.33	0.20	+	+	1 / 50
	30296	PS	Black	85.40 x 127.60 x 14.40	6.50 x 10.80	0.33	0.20	+	+	1 / 50
	30396	PS	White	85.40 x 127.60 x 14.40	6.50 x 10.80	0.33	0.20	-	-	1 / 50
	30496	PS	Black	85.40 x 127.60 x 14.40	6.50 x 10.80	0.33	0.20	-	-	1 / 50

Square Dish

Square Dishes for cell culture provide gridded surface area for confirming cell location, and are ideal for cell counting.

- Large culture area compared to conventional round cell culture dishes
- Available with grids for counting or confirmation of location
- Optically clear and flat surface for microscopy
- Effective gas exchange lid inner design
- Excellent stackability

- Non-pyrogenic
- Non-cytotoxic
- DNase / RNase-free
- Human DNA-free

**Square Dish**

Type	Cat. No.	Material	External Dimensions w x l x h (mm)	Well Dimensions w x l x h (mm)	Growth Area (cm ²)	Surface Treatment	Sterile	Packaging
	10125	PS	126.40 x 126.40 x 20.00	118.70 x 118.70 x 11.60	139.00	+	+	5 / 60

Tray Plate

SPL's Tray Plates provide a larger surface area and easy handling compared to those of conventional round type dishes. The external dimensions of Tray Plates are identical to those of standard SPL Cell Culture Plates for broader applications.

- Optically clear & flat for microscopy
- Effective gas exchange lid inner design

- Non-pyrogenic
- Non-cytotoxic
- DNase / RNase-free
- Human DNA-free

**Tray Plate**

Type	Cat. No.	Material	External Dimensions w x l x h (mm)	Well Dimensions w x l x h (mm)	Growth Area (cm ²)	Surface Treatment	Sterile	Packaging
	30001	PS	127.94 x 85.50 x 16.25	109.64 x 73.46 x 11.60	80.54	+	+	1 / 50

Cell Culture



Roller Bottle

SPL Life Sciences provides Roller Bottles for scale-up culture of cells. Cylindrical vessel structure of the Roller Bottles, combined with constant rotating culture procedure, provides a very economical means for cultivating large numbers of cells with using minimal amount of necessary reagents and labor.

- Prevention of gradient formation through gentle agitation / rotation
- Superior gas exchanging environment for anchorage dependent cells
- Optically clear for microscopy
- Surface treated bottles for anchorage-dependent cell culture (Cat. No. 55085, 55285)
- Non-treated bottles for suspension cell culture (Cat. No. 55185, 55385)
- Non-pyrogenic
- Non-cytotoxic
- Non-Hemolytic
- DNase / RNase-free
- Human DNA-free



Roller Bottle

Type	Cat. No.	Material (Body / Cap)	Cap Type	Surface Type	Growth Area (cm ²)	Surface Treatment	Sterile	Packaging
	55085	PS / HDPE	Plug	Smooth	850.00	+	+	2 / 40
	55185	PS / HDPE	Plug	Smooth	850.00	-	+	2 / 40
	55285	PS / HDPE	Filter	Smooth	850.00	+	+	2 / 40
	55385	PS / HDPE	Filter	Smooth	850.00	-	+	2 / 40





Erlenmeyer Flask

SPL Life Sciences provides Erlenmeyer Flasks, suitable for animal cell and microbial suspension culture. The flask is designed to allow efficient suspension culture, provided in five different volumes, and are all sterilized before the release.

- Suitable for suspension cultures (animal cells, bacteria, fungi, plant callus, etc.)
- Require shaking apparatus (optimization of cell seeding density and working volume is recommended, depending on the type of cell)
- Plug & filter caps are available for all flask types
- Non-treated
- Durable & transparent polycarbonate
- Autoclavable
- Used silicone washer cap for sealing (Cat.No. 73003, 74003)
- Non-pyrogenic
- Non-cytotoxic
- DNase / RNase-free
- Human DNA-free



Erlenmeyer Flask

Type		Cat. No.	Material (Body / Cap)	Cap Type	Bottom Type	Total Vol. (ml)	Sterile	Packaging
	○	73250	PC / PP	Plug	Plain	250.00	+	1 / 8
	⊙	74250	PC / PP	Filter	Plain	250.00	+	1 / 8
	○	73500	PC / PP	Plug	Plain	500.00	+	1 / 8
	⊙	74500	PC / PP	Filter	Plain	500.00	+	1 / 8
	○	73000	PC / PP	Plug	Plain	1,000.00	+	1 / 4
	⊙	74000	PC / PP	Filter	Plain	1,000.00	+	1 / 4
	○	73002	PC / PP	Plug	Plain	2,000.00	+	1 / 6
	⊙	74002	PC / PP	Filter	Plain	2,000.00	+	1 / 6
	○	73003	PC / PP	Plug	Plain	3,000.00	+	1 / 4
	⊙	74003	PC / PP	Filter	Plain	3,000.00	+	1 / 4

Cell Culture











Cell Culture Square Bottle

SPL Life Sciences provides Cell Culture Square Bottles, suitable for animal cell and microbial suspension culture. The shape of the bottle is specially designed to cause turbulent flow of media when physically swirled for more effective solution mixing and oxygen supply. The Square Bottles are provided in four different volumes, which are all sterilized before the release.

- Suitable for suspension cultures (animal cells, bacteria, fungi, plant callus, etc.)
- Require shaking apparatus (optimization of cell seeding density and working volume is recommended, depending on the type of cell)
- The square-shaped bottle is intended to cause turbulent flow like baffled Erlenmeyer Flask
- Plug & filter caps are available for all bottle types
- Non-treated
- Transparent PET
- Non-autoclavable
- Non-pyrogenic
- Non-cytotoxic
- DNase / RNase-free
- Human DNA-free

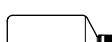

Cell Culture Square Bottle

Type	Cat. No.	Material (Bottle / Cap)	Cap Type	Total Vol.(ml)	Sterile	Packaging
	 51125	PET / HDPE	Plug	125.00	+	1 / 36
	 51126	PET / HDPE	Filter	125.00	+	1 / 36
	 51250	PET / HDPE	Plug	250.00	+	1 / 30
	 51251	PET / HDPE	Filter	250.00	+	1 / 30
	 51500	PET / HDPE	Plug	500.00	+	1 / 15
	 51501	PET / HDPE	Filter	500.00	+	1 / 15
	 51000	PET / HDPE	Plug	1,000.00	+	1 / 8
	 51001	PET / HDPE	Filter	1,000.00	+	1 / 8

Bioreactor



SPL Bioreactors are designed mammalian cells and micro-organism under suspension condition. Tubes are sterilized after complete packaging to eliminate contamination. The air circulation within the reactor can be controlled by the dial on the center of the reactor cap, providing 4 levels of ventilation.

- Four different levels of ventilation (dial type) on the cap
- 0.2 µm Acrylic copolymer filter membrane
- Suitable for suspension culture

- Non-pyrogenic
- Non-cytotoxic
- DNase / RNase-free
- Human DNA-free

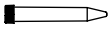

Bioreactor

Type	Cat. No.	Material (Tube / Cap / Filter / Dial)	Cap Type	Total Vol. (ml)	Surface Treatment	Sterile	Packaging
	51315	PP / HDPE / Acrylic copolymer / PS	Filter	15.00	-	+	3 / 90
	50351	PP / HDPE / Acrylic copolymer / PS	Filter	50.00	-	+	3 / 90

Cell Culture Module Plate



The Cell Culture Module Plate is designed to be assembled into a desired shape through a combination of 6-well and 24-well insert depending on the purpose of the experiment. Inserts can be observed under a microscope in both attached and detached states of the plate and have the same performance as the existing Cell Culture Plate. It is efficient and economical because various types of cells can be cultured simultaneously on a single plate and harvested by time period

- Designed to prevent cross contamination
- Homogeneous cell culture
- Same well size as the existing Cell Culture Plate (Cat.No. 30006, 30024)

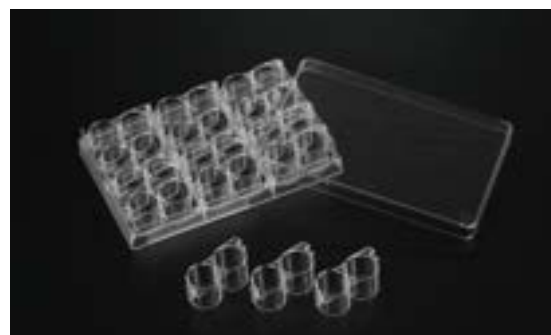
- Non-pyrogenic
- Non-cytotoxic
- DNase / RNase-free
- Human DNA-free



Cell Culture Module Plate

Type	Cat. No.	Material	Insert Type	Well Dimension d x h(mm)	Growth Area (cm ²)	Working Vol. (ml)	Surface Treatment	Sterile	Packaging
	300906	PS	6well	35.00 x 17.40	9.60	2.00	+	+	6 Inserts / Plate 25 Plates / Box
	300924	PS	24well (Long)	15.60 x 17.40	1.90	1.00	+	+	12 Inserts / Plate 25 Plates / Box

Cell Culture

1-2. SPLCoat™



Interactions of cells with surrounding extracellular environment actively regulate cellular functions, including adhesion, migration, differentiation, proliferation, invasion and survival. Extracellular matrix (ECM) proteins, such as collagen and laminin are readily used to promote cellular adhesion growth in *in vitro* cell-based applications.

SPL Life Sciences offers a wide range of ECM protein-coated products to meet individual needs. No washing is required before use and all products are optically clear for microscopy.

Collagen Type I :

the most abundant protein in human body in the form of collagen fibers, induces stronger cell binding to the surface

See page 32

Poly-D-Lysine (PDL) :

a synthetic form of polymeric amino acid, induces stronger cell binding

See page 33

Laminin :

a major protein in basal lamina that is frequently used for stem cell cultures playing critical roles in cell differentiation and migration

See page 34

Collagen Type IV :

a type of collagen found primarily in the basal lamina that is a layer of extracellular matrix secreted by the epithelial cells

See page 35

Fibronectin :

a high molecular glycoprotein found abundantly in blood and connective tissues

See page 36

Matrix™ :

a major protein in Engbreth-Holm-Swarm (EHS) mouse tumor cells that is frequently used for stem cell culture playing critical roles in cell differentiation, angiogenesis and tumorigenesis models

See page 37

SPLCoat™ Materials

	Cell Culture Flask	Cell Culture Dish	Cell Culture Slide	Cell Culture Plate
Collagen Type I	•	•		•
PDL	•	•	•	•
Laminin	•	•		•
Collagen Type IV		•	•	•
Fibronectin	•	•	•	•
Matrix™	•	•		•

Cell Culture

Collagen Type I Coated Ware

SPL Life Sciences provides a wide range of high-quality Collagen Type I coated products. All Collagen Type I coated products are produced with optically clear and high quality polymers for microscopy.

- Source: Rat Tail Tendon
- No washing required before use
- Shelf life: 6 months at room temperature



Flask

Type	Cat. No.	Material (Body / Cap)	Cap Type	Growth Area (cm ²)	Working Vol. (ml)	Packaging
	75025	PS / HDPE	Filter	25.00	7.00	5 / 10
	75125	PS / HDPE	Plug	25.00	7.00	5 / 10
	75075	PS / HDPE	Filter	75.00	25.00	5 / 10

Dish

Type	Cat. No.	Material	Dish Style d x h (mm)	Internal Dimensions d x h (mm)	Growth Area (cm ²)	Working Vol. (ml)	External Grip	Packaging
	21035	PS	35.00 x 10.00	35.00 x 9.60	9.40	3.00	+	5 / 20
	21060	PS	60.00 x 15.00	52.80 x 12.80	21.50	5.00	+	5 / 20
	21100	PS	90.00 x 20.00	86.26 x 17.70	57.50	12.50	-	5 / 10

Plate

Type	Cat. No.	Material	Plate Type	External Dimensions w x l x h (mm)	Well Dimensions d x h (mm)	Growth Area (cm ²)	Working Vol. (ml)	Packaging
	39006	PS	6well	85.40 x 127.60 x 20.20	35.00 x 17.50	9.60	3.00	1 / 5
	39012	PS	12well	85.40 x 127.60 x 20.20	21.90 x 17.50	3.80	2.00	1 / 5
	39024	PS	24well	85.40 x 127.60 x 20.20	15.50 x 17.50	1.90	1.00	1 / 5
	39048	PS	48well	85.40 x 127.60 x 20.20	9.75 x 17.50	0.75	0.50	1 / 5
	39096	PS	96well	85.40 x 127.60 x 14.40	6.50 x 10.80	0.33	0.20	1 / 5

Poly-D-Lysine Coated Ware

SPL Life Sciences provides a wide range of high-quality Poly-D-Lysine coated products. All Poly-D-Lysine coated products are produced with optically clear and high quality polymers for microscopy.



- Source: Synthetic
- No washing required before use
- Shelf life: 6 months at room temperature







Flask

Type	Cat. No.	Material (Body / Cap)	Cap Type	Growth Area (cm ²)	Working Vol. (ml)	Packaging
	76075	PS / HDPE	Filter	75.00	25.00	5 / 10

Dish

Type	Cat. No.	Material	Dish Style d x h (mm)	Internal Dimensions d x h (mm)	Growth Area (cm ²)	Working Vol. (ml)	External Grip	Packaging
	22100	PS	90.00 x 20.00	86.26 x 17.70	57.50	12.50	-	5 / 10
	22150	PS	150.00 x 25.00	140.20 x 23.30	148.00	35.00	-	5 / 5

Plate

Type	Cat. No.	Material	Plate Type	External Dimensions w x l x h (mm)	Well Dimensions d x h (mm)	Growth Area (cm ²)	Working Vol. (ml)	Packaging
	39206	PS	6well	85.40 x 127.60 x 20.20	35.00 x 17.50	9.60	3.00	1 / 5
	39212	PS	12well	85.40 x 127.60 x 20.20	21.90 x 17.50	3.80	2.00	1 / 5
	39224	PS	24well	85.40 x 127.60 x 20.20	15.50 x 17.50	1.90	1.00	1 / 5
	39296	PS	96well	85.40 x 127.60 x 14.40	6.50 x 10.80	0.33	0.20	1 / 5

Slide

Type	Cat. No.	Material (Chamber / Slide / Holder)	Chamber Color	Growth Area (cm ²)	Working Vol. (ml)	Packaging
	30308	PS / Glass / PP	Clear	0.98	0.20 – 0.60	6 / 12

Cell Culture

Laminin Coated Ware

SPL Life Sciences provides a wide range of high-quality Laminin coated products. All Laminin coated products are produced with optically clear and high quality polymers for microscopy.



- Source: Engelbreth-Holm-Swarm (EHS) mouse tumor
- No washing required before use
- Shelf life: 3 months at refrigerated





Flask

Type	Cat. No.	Material (Body / Cap)	Cap Type	Growth Area (cm ²)	Working Vol. (ml)	Packaging
	77125	PS / HDPE	Plug	25.00	7.00	5 / 10

Dish

Type	Cat. No.	Material	Dish Style d x h (mm)	Internal Dimensions d x h (mm)	Growth Area (cm ²)	Working Vol. (ml)	External Grip	Packaging
	23035	PS	35.00 x 10.00	35.00 x 9.60	9.40	3.00	+	5 / 20
	23100	PS	90.00 x 20.00	86.26 x 17.70	57.50	12.50	-	5 / 10

Plate

Type	Cat. No.	Material	Plate Type	External Dimensions w x l x h (mm)	Well Dimensions d x h (mm)	Growth Area (cm ²)	Working Vol. (ml)	Packaging
	39312	PS	12well	85.40 x 127.60 x 20.20	21.90 x 17.50	3.80	2.00	1 / 5
	39348	PS	48well	85.40 x 127.60 x 20.20	9.75 x 17.50	0.75	0.50	1 / 5
	39396	PS	96well	85.40 x 127.60 x 14.40	6.50 x 10.80	0.33	0.20	1 / 5



Collagen Type IV Coated Ware

SPL Life Sciences provides a wide range of Collagen Type IV coated products with high quality. All Collagen Type IV coated products are produced with optically clear and high quality polymers for microscopy.

- Source: Engelbreth-Holm-Swarm (EHS) lathrytic mouse tumor
- No washing required before use
- Shelf life: 3 months at refrigerated



Flask

Type	Cat. No.	Material (Body / Cap)	Cap Type	Growth Area (cm ²)	Working Vol. (ml)	Packaging
	78025	PS / HDPE	Filter	25.00	7.00	5 / 10
	78075	PS / HDPE	Filter	75.00	25.00	5 / 10

Dish

Type	Cat. No.	Material	Dish Style d x h (mm)	Internal Dimensions d x h (mm)	Growth Area (cm ²)	Working Vol. (ml)	External Grip	Packaging
	24100	PS	90.00 x 20.00	86.26 x 17.70	57.50	12.50	-	5 / 10

Slide

Type	Cat. No.	Material (Chamber / Slide / Holder)	Chamber Color	Growth Area (cm ²)	Working Vol. (ml)	Packaging
	30608	PS / Glass / PP	Clear	0.98	0.20 – 0.60	6 / 12

Cell Culture

Fibronectin Coated Ware

SPL Life Sciences provides a wide range of high-quality Fibronectin coated products. All Fibronectin coated products are produced with optically clear and high quality polymers for microscopy.

- Source: Human plasma
- No washing required before use
- Shelf life: 3 months at refrigerated



Flask

Type	Cat. No.	Material (Body / Cap)	Cap Type	Growth Area (cm ²)	Working Vol. (ml)	Packaging
	79125	PS / HDPE	Plug	25.00	7.00	5 / 10
	79075	PS / HDPE	Filter	75.00	25.00	5 / 10

Dish

Type	Cat. No.	Material	Dish Style d x h (mm)	Internal Dimensions d x h (mm)	Growth Area (cm ²)	Working Vol. (ml)	External Grip	Packaging
	25035	PS	35.00 x 10.00	35.00 x 9.60	9.40	3.00	+	5 / 20
	25100	PS	90.00 x 20.00	86.26 x 17.70	57.50	12.50	-	5 / 10
	25150	PS	150.00 x 25.00	140.20 x 23.30	148.00	35.00	-	5 / 5

Plate

Type	Cat. No.	Material	Plate Type	External Dimensions w x l x h (mm)	Well Dimensions d x h (mm)	Growth Area (cm ²)	Working Vol. (ml)	Packaging
	39524	PS	24well	85.40 x 127.60 x 20.20	15.50 x 17.50	1.90	1.00	1 / 5
	39596	PS	96well	85.40 x 127.60 x 14.40	6.50 x 10.80	0.33	0.20	1 / 5

Slide

Type	Cat. No.	Material (Chamber / Slide / Holder)	Chamber Color	Growth Area (cm ²)	Working Vol. (ml)	Packaging
	30704	PS / Glass / PP	Clear	2.13	0.50 – 1.30	6 / 12
	30708	PS / Glass / PP	Clear	0.98	0.20 – 0.60	6 / 12

Matrix™ Coated Ware

SPL Life Sciences provides a wide range of high-quality Matrix™ coated products. All Matrix™ coated products are produced with optically clear and high quality polymers for microscopy.





- Source Engelbreth-Holm-Swarm (EHS) mouse tumor
- No washing required before use
- Shelf life: 3 months at refrigerated





Flask

Type	Cat. No.	Material (Body / Cap)	Cap Type	Growth Area (cm ²)	Working Vol. (ml)	Packaging
	710025	PS / HDPE	Filter	25.00	7.00	5 / 10

Dish

Type	Cat. No.	Material	Dish Style d x h (mm)	Internal Dimensions d x h (mm)	Growth Area (cm ²)	Working Vol. (ml)	External Grip	Packaging
	27035	PS	35.00 x 10.00	35.00 x 9.60	9.40	3.00	+	5 / 20
	27060	PS	60.00 x 15.00	52.80 x 12.80	21.50	5.00	+	5 / 20
	27100	PS	90.00 x 20.00	86.26 x 17.70	57.50	12.50	-	5 / 10
	27150	PS	150.00 x 25.00	140.20 x 23.30	148.00	35.00	-	5 / 5

Plate

Type	Cat. No.	Material	Plate Type	External Dimensions d x h (mm)	Well Dimensions d x h (mm)	Growth Area (cm ²)	Working Vol. (ml)	Packaging
	39606	PS	6well	85.40 x 127.60 x 20.20	35.00 x 17.50	9.60	3.00	1 / 5
	39612	PS	12well	85.40 x 127.60 x 20.20	21.90 x 17.50	3.80	2.00	1 / 5
	39624	PS	24well	85.40 x 127.60 x 20.20	15.50 x 17.50	1.90	1.00	1 / 5

Cell Culture

1-3. Cellular Imaging

SPL Cellular Imaging products are designed to maximize convenience for a broad range of applications, including confocal microscopy, fluorescence microscopy, live cell imaging, and fluorescence-based analysis.

- Efficient light transmission and minimal auto-fluorescence to achieve the most accurate results
- Black colored products are designed to prevent well-to-well light interference for reliable results
- Various bottom types are available for a wide range of applications

	Surfaces			Materials			
	Cell Culture Treated	Non-Treated	SPLCoat™	Glass	DLux	FLux	PS
Black Plate	•	•		•		•	•
Cell Culture Slide	•	•	•	•	•	•	
Cell Culture Slide Hybridwell™	•	•		•	•	•	
Confocal Dish & Plate	•	•				•	

Detailed information on DLux & FLux – Light Transmission, Autofluorescence, Confocal Images

Fig. 1. Auto-fluorescence at 400 nm SPL vs A Brand

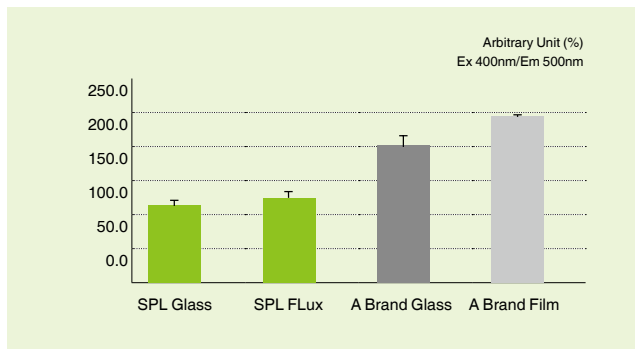

Fig. 2. % Transmittance

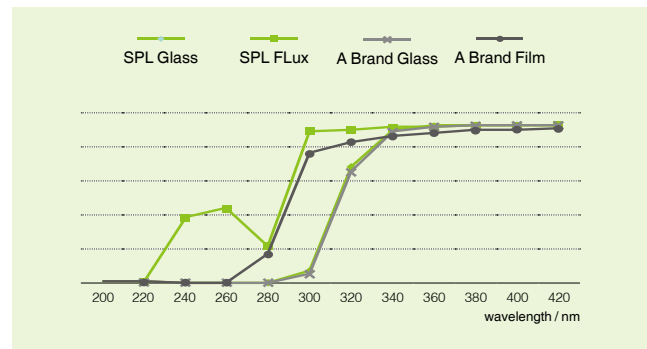

Fig. 3. Adhesion of L-929 cells SPL vs A Brand

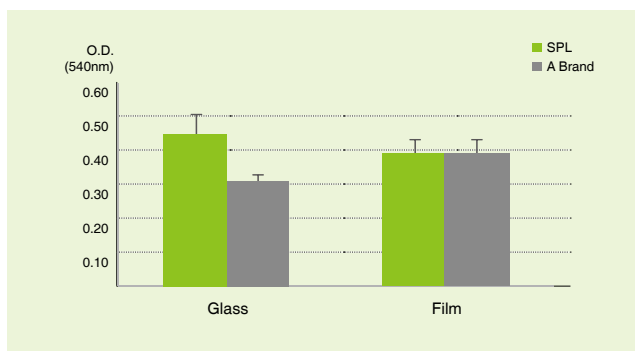
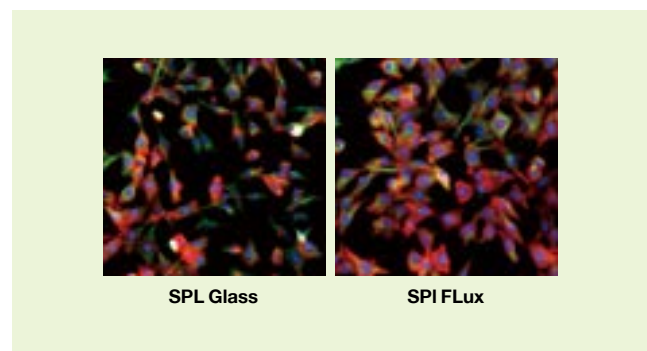

Fig. 4. Fluorescence cellular images on SPL Glass / FLux







Black Plate

SPL Black Plate has low auto-fluorescence with efficient light blocking ability to obtain the most accurate result in fluorescence experiments. Moreover, microscopic observation can be done simultaneously with fluorescence experiment due to its highly transparent bottom.

- Black wall / Clear bottom
- Bottom materials: Glass / FLux / PS
- Designed to prevent cross contamination
- Effective gas exchange lid inner design
- Alphanumeric labeling
- Individual packaging in plastic tray
- (Cat. No. 33196, 33212, 33224, 33296, 33312, 33324, 332384, 333384)
- Non-pyrogenic
- Non-cytotoxic
- DNase / RNase-free
- Human DNA-free



Black Plate

Type	Cat. No.	Material (Plate /Bottom)	Bottom Type	External Dimensions w x l x h (mm)	Well Dimensions d x h (mm)	Growth Area (cm ²)	Total Vol. (ml)	Working Vol. (ml)	Surface Treatment	Sterile	Packaging
12well											
	33212	PS / FLux	Flat	85.40 x 127.60 x 20.20	21.90 x 17.50	3.80	3.00	2.00	+	+	1 / 10
	33312	PS / PS	Flat	85.40 x 127.60 x 20.20	21.90 x 17.50	3.80	3.00	2.00	+	+	1 / 10
24well											
	33224	PS / FLux	Flat	85.40 x 127.60 x 20.20	15.50 x 17.50	1.90	2.00	1.00	+	+	1 / 10
	33324	PS / PS	Flat	85.40 x 127.60 x 20.20	15.50 x 17.50	1.90	2.00	1.00	+	+	1 / 10
96well											
	33196	PS / Glass	Flat	85.40 x 127.60 x 14.40	6.50 x 10.80	0.33	0.30	0.20	-	+	1 / 20
	33296	PS / FLux	Flat	85.40 x 127.60 x 14.40	6.50 x 10.80	0.33	0.30	0.20	+	+	1 / 20
	33396	PS / PS	Flat	85.40 x 127.60 x 14.40	6.50 x 10.80	0.33	0.30	0.20	+	+	5 / 25
384well											
	332384	PS / FLux	Flat	85.40 x 127.60 x 14.40	3.00 x 11.50	0.07	0.20	0.10	+	+	1 / 10
	333384	PS / PS	Flat	85.40 x 127.60 x 14.40	3.00 x 11.50	0.07	0.20	0.10	+	+	1 / 10

Cell Culture



White Plate

SPL White Plate is suitable for obtaining amplified signals in a luminescence assay with high reflection and minimized cross-talk. In addition, the highly transparent bottom provides an optimal environment for microscopic observation at once.

- White wall / Clear bottom
- Bottom materials: Glass / FLux / PS
- Designed to prevent cross contamination
- Effective gas exchange lid inner design
- Alphanumeric labeling
- Individual packaging in plastic tray
- (Cat. No. 33496, 33596, 335384, 336384)
- Non-pyrogenic
- Non-cytotoxic
- DNase / RNase-free
- Human DNA-free



White Plate

Type	Cat. No.	Material (Plate /Bottom)	Bottom Type	External Dimensions w x l x h (mm)	Well Dimensions d x h (mm)	Growth Area (cm ²)	Total Vol. (ml)	Working Vol. (ml)	Surface Treatment	Sterile	Packaging
96well											
	33496	PS / Glass	Flat	85.40 x 127.60 x 14.40	6.50 x 10.80	0.33	0.30	0.20	-	+	1 / 10
	33596	PS / FLux	Flat	85.40 x 127.60 x 14.40	6.50 x 10.80	0.33	0.30	0.20	+	+	1 / 10
	33696	PS / PS	Flat	85.40 x 127.60 x 14.40	6.50 x 10.80	0.33	0.30	0.20	+	+	5 / 25
384well											
	335384	PS / FLux	Flat	85.40 x 127.60 x 14.40	3.00 x 11.50	0.07	0.20	0.10	+	+	1 / 10
	336384	PS / PS	Flat	85.40 x 127.60 x 14.40	3.00 x 11.50	0.07	0.20	0.10	+	+	1 / 10

Coverslip

The material used for SPL Coverslips is FLux film that exhibits superior cell attachment with optimal thickness for high resolution microscopy.

- Resistant to breakage and various solvents
- Suitable for specimen preparation under optical microscopy
- Non-autoclavable
- Non-pyrogenic
- Non-cytotoxic
- DNase / RNase-free
- Human DNA-free

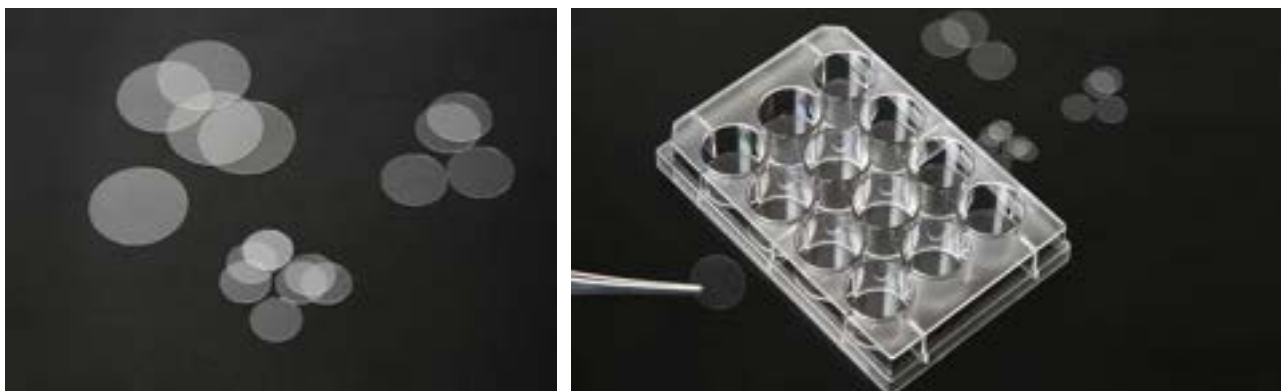

Coverslip

Type	Cat. No.	Material	Fits into	Dimension (mm)	Sterile	Packaging
○	20009	FLux	48well	9.00	+	100 / 200
○	20012	FLux	24well	12.00	+	100 / 200
○	20018	FLux	12well	18.00	+	100 / 200
○	20025	FLux	6well	25.00	+	50 / 200

Microscopy Coverslip

Microscopy Coverslip is suitable for microscopic observation, designed as a square or rectangle for convenience in experiments.

- Resistant to breakage and various solvents
- Suitable for cell straining, mounting, embedding
- Non-autoclavable
- Non-pyrogenic
- Non-cytotoxic
- DNase / RNase-free
- Human DNA-free



Microscopy Coverslip

Type	Cat. No.	Material	Dimensions (mm)	Sterile	Packaging
□	20022	FLux	22.00 x 22.00	-	50 / 200
□	20052	FLux	52.00 x 25.00	-	50 / 200

Cell Culture

Cell Culture Slide I

SPL's Cell Culture Slides are designed for various cell-based experiments, including but not limited to virus and toxicity tests and immunocytological experiments. Cell Culture Slides provide removable chamber that enables cell growth directly on the microscopic slide, convenient for staining and microscopic examination without cell transfer. Chambers with various well numbers and colors are available for different applications. With new additions of novel culture surfaces (i.e. DLux & FLux), the Cell Culture Slides have been diversified with improved efficacy.

- Convenient for microscopic observation
- Bottom materials: Glass / DLux / FLux (no surface treatment for glass bottom)
- Chamber color: Clear / White / Black
- Easy open flip for chamber & slide disassembly
- No chemical adhesives used
- Designed to prevent cross contamination
- Alphanumeric labeling
- Packing trays can be used as incubation racks in CO₂ incubators
- Non-pyrogenic
- Non-cytotoxic
- DNase / RNase-free
- Human DNA-free

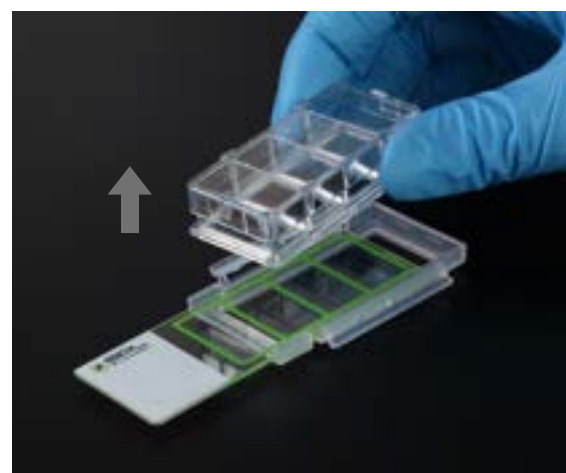
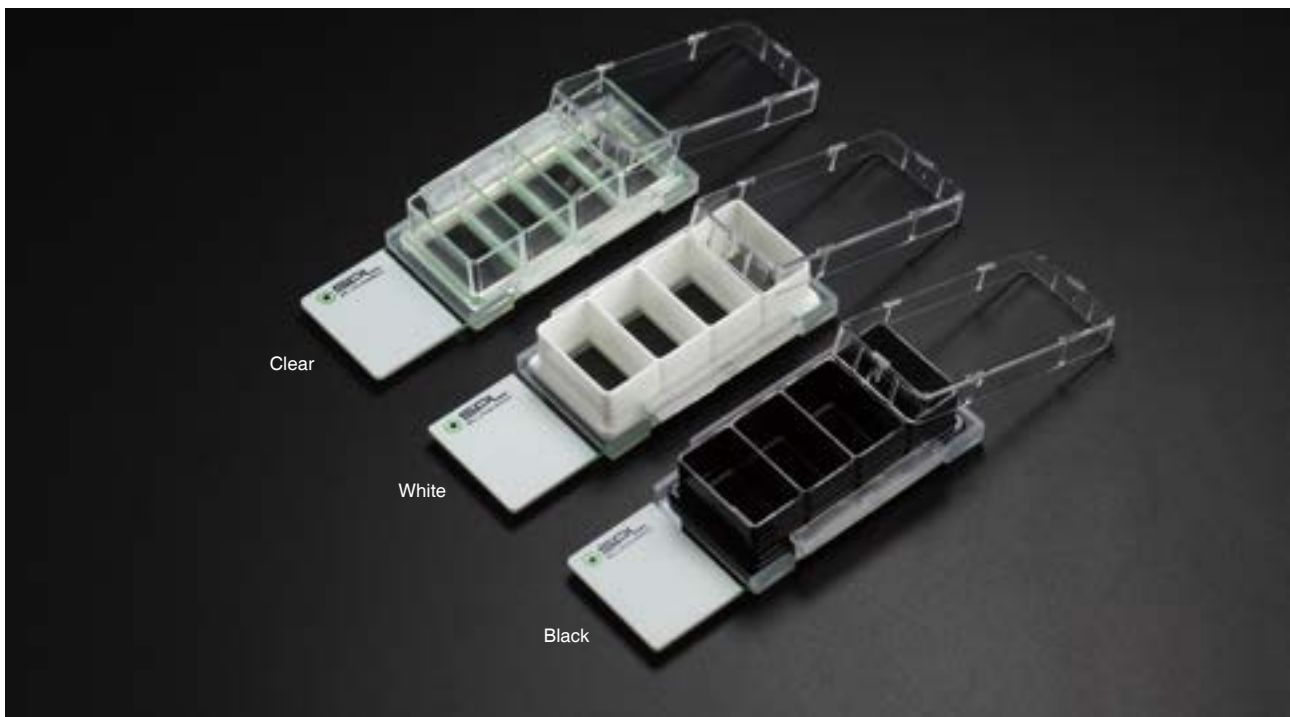

continued on next page

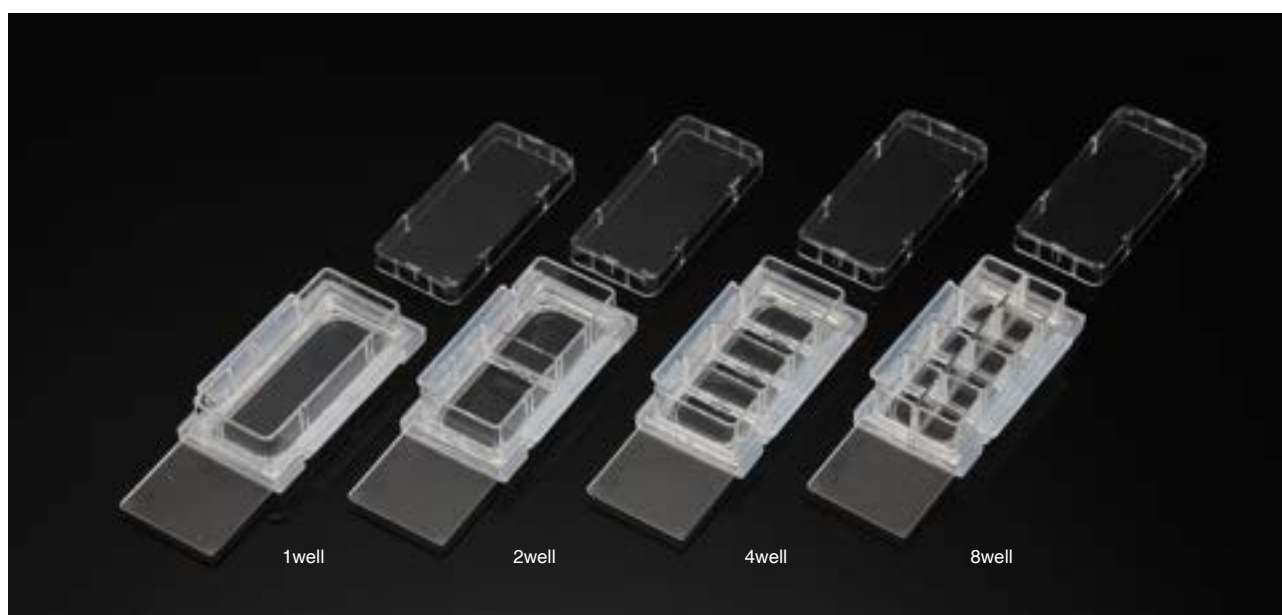

Cell Culture Slide I

Type	Cat. No.	Material (Chamber / Slide / Holder)	Chamber Color	Growth Area / Well (cm ²)	Working Vol. / Well (ml)	Surface Treatment	Sterile	Packaging
1well								
	30101	PS / Glass / PP	Clear	9.40	2.50 – 5.50	-	+	6 / 12
	30111	PS / Glass / PP	Black	9.40	2.50 – 5.50	-	+	6 / 12
	30121	PS / Glass / PP	White	9.40	2.50 – 5.50	-	+	6 / 12
	30401	PS / DLux / PP	Clear	9.40	2.50 – 5.50	+	+	6 / 12
	30501	PS / FLux / PP	Clear	9.40	2.50 – 5.50	+	+	6 / 12
2well								
	30102	PS / Glass / PP	Clear	4.55	1.20 – 2.50	-	+	6 / 12
	30112	PS / Glass / PP	Black	4.55	1.20 – 2.50	-	+	6 / 12
	30122	PS / Glass / PP	White	4.55	1.20 – 2.50	-	+	6 / 12
	30402	PS / DLux / PP	Clear	4.55	1.20 – 2.50	+	+	6 / 12
	30502	PS / FLux / PP	Clear	4.55	1.20 – 2.50	+	+	6 / 12
4well								
	30104	PS / Glass / PP	Clear	2.13	0.50 – 1.30	-	+	6 / 12
	30114	PS / Glass / PP	Black	2.13	0.50 – 1.30	-	+	6 / 12
	30124	PS / Glass / PP	White	2.13	0.50 – 1.30	-	+	6 / 12
	30404	PS / DLux / PP	Clear	2.13	0.50 – 1.30	+	+	6 / 12
	30504	PS / FLux / PP	Clear	2.13	0.50 – 1.30	+	+	6 / 12
8well								
	30108	PS / Glass / PP	Clear	0.98	0.20 – 0.60	-	+	6 / 12
	30118	PS / Glass / PP	Black	0.98	0.20 – 0.60	-	+	6 / 12
	30128	PS / Glass / PP	White	0.98	0.20 – 0.60	-	+	6 / 12
	30408	PS / DLux / PP	Clear	0.98	0.20 – 0.60	+	+	6 / 12
	30508	PS / FLux / PP	Clear	0.98	0.20 – 0.60	+	+	6 / 12

For surface coated Cell Culture Slide (SPLCoat™- Collagen type IV, Poly-D-Lysine, Fibronectin) see page 30 - 37

Cell Culture

Cell Culture Slide II

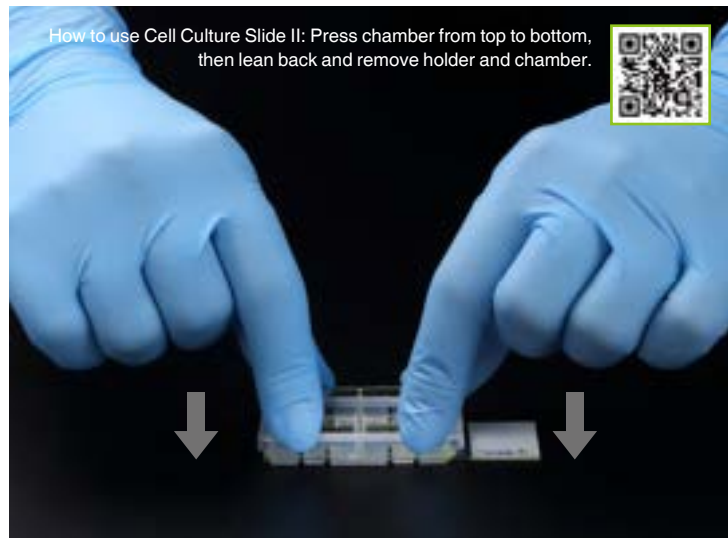

Cell Culture Slide II

Type	Cat. No.	Material (Chamber / Slide / Holder)	Chamber Color	Growth Area / Well (cm ²)	Working Vol. / Well (ml)	Surface Treatment	Sterile	Packaging
1well								
	31101	PS / Glass / PP	Clear	9.40	2.50 – 5.50	-	+	6 / 12
	31111	PS / Glass / PP	Black	9.40	2.50 – 5.50	-	+	6 / 12
	31121	PS / Glass / PP	White	9.40	2.50 – 5.50	-	+	6 / 12
	31401	PS / DLux / PP	Clear	9.40	2.50 – 5.50	+	+	6 / 12
	31501	PS / FLux / PP	Clear	9.40	2.50 – 5.50	+	+	6 / 12
2well								
	31102	PS / Glass / PP	Clear	4.55	1.20 – 2.50	-	+	6 / 12
	31112	PS / Glass / PP	Black	4.55	1.20 – 2.50	-	+	6 / 12
	31122	PS / Glass / PP	White	4.55	1.20 – 2.50	-	+	6 / 12
	31402	PS / DLux / PP	Clear	4.55	1.20 – 2.50	+	+	6 / 12
	31502	PS / FLux / PP	Clear	4.55	1.20 – 2.50	+	+	6 / 12
4well								
	31104	PS / Glass / PP	Clear	2.13	0.50 – 1.30	-	+	6 / 12
	31114	PS / Glass / PP	Black	2.13	0.50 – 1.30	-	+	6 / 12
	31124	PS / Glass / PP	White	2.13	0.50 – 1.30	-	+	6 / 12
	31404	PS / DLux / PP	Clear	2.13	0.50 – 1.30	+	+	6 / 12
	31504	PS / FLux / PP	Clear	2.13	0.50 – 1.30	+	+	6 / 12
8well								
	31108	PS / Glass / PP	Clear	0.98	0.20 – 0.60	-	+	6 / 12
	31118	PS / Glass / PP	Black	0.98	0.20 – 0.60	-	+	6 / 12
	31128	PS / Glass / PP	White	0.98	0.20 – 0.60	-	+	6 / 12
	31408	PS / DLux / PP	Clear	0.98	0.20 – 0.60	+	+	6 / 12
	31508	PS / FLux / PP	Clear	0.98	0.20 – 0.60	+	+	6 / 12

Co Culture Slide

Co Culture Slide is an imaging product that is designed to simplify proceed with the co-culture. Different cell lines are cultivated separately, but the control of the medium volume allows the substances in the medium can be shared with each other. Through co-culture, you can intended for checking signal exchange, chemotaxis, and molecular transport between cell lines.

- Convenient for microscopic observation
- Bottom materials: DLux / FLux
- Easy open flip for chamber & slide disassembly
- No chemical adhesives used
- Packing trays can be used as incubation racks in CO₂ incubators
- Domestic sales only
- Non-pyrogenic
- Non-cytotoxic
- DNase / RNase-free
- Human DNA-free



Co Culture Slide

Type	Cat. No.	Major well	Minor well (each Major well)	Material (Chamber/Slide/Holder)	Growth Area (cm ²)	Major well Working Vol. (ml)	Minor well Working Vol. (ml)	Surface Treatment	Sterile	Packaging
	32402	2	4	PS / DLux / PP	0.98	1.20 – 2.50	0.15	+	+	6 / 12
	32502	2	4	PS / FLux / PP	0.98	1.20 – 2.50	0.15	+	+	6 / 12
	32404	4	2	PS / DLux / PP	0.98	0.50 – 1.30	0.15	+	+	6 / 12
	32504	4	2	PS / FLux / PP	0.98	0.50 – 1.30	0.15	+	+	6 / 12

Cell Culture

Cell Culture Slide Hybridwell™

Cell Culture Slide Hybridwell™ is a combination of conventional cell culture flask and single well slide, providing better and safer handling of samples.

- Convenient for microscopic observation
- Bottom materials: Glass / DLux / FLux (no surface treatment for glass bottom)
- Chamber color: Clear
- Easy open lip for chamber & slide disassembly
- No chemical adhesives used
- Packing trays can be used as incubation racks in CO₂ incubators
- Non-pyrogenic
- Non-cytotoxic
- DNase / RNase-free
- Human DNA-free



Cell Culture Slide Hybridwell™

Type	Cat. No.	Material (Chamber / Slide / Holder)	Chamber Color	Growth Area (cm ²)	Working Vol. (ml)	Surface Treatment	Sterile	Packaging
	33101	PS / Glass / PP	Clear	9.00	2.50 – 5.50	-	+	6 / 12
	33201	PS / DLux / PP	Clear	9.00	2.50 – 5.50	+	+	6 / 12
	33301	PS / FLux / PP	Clear	9.00	2.50 – 5.50	+	+	6 / 12

Confocal Dish & Plate

SPL confocal products allow researchers to acquire high resolution microscopic images of cells in 35 mm culture dishes or 6well plates. Low auto-fluorescence Glass and FLux, ideal for confocal microscopy, phase contrast microscopy, live cell imaging, and micromanipulations, are used.

- Bottom materials: Glass / FLux
- Dish color: Clear / Black
- Dish size: 35 Ø
- 4well Dish: (Cat. No. 104350, 214350)
- Plate size: 6well Plate (Cat. No. 30106, 30206, 230106, 230206)
- Hole size: 13 Ø / 20 Ø / 25 Ø
- Insert Type: Cat. No. 100351
- Non-pyrogenic
- Non-cytotoxic
- DNase / RNase-free
- Human DNA-free



continued on next page



Confocal Dish & Plate

Type	Cat. No.	Material	Color	External Dimensions (mm)	Internal Dimensions (mm)	Hole	Confocal Region (cm ²)	Working Vol. (ml)	Surface Treatment	Sterile	Packaging
Confocal Dish											
	100350	PS / Glass	Clear	35.00 x 10.00	34.30 x 9.30	13 Ø	1.33	3.00	-	+	5 / 100
	100351	PS / Glass	Clear	35.00 x 10.00	34.30 x 9.30	-	-	3.00	-	+	10 / 500
	101350	PS / Glass	Clear	35.00 x 10.00	34.30 x 9.30	20 Ø	3.14	3.00	-	+	5 / 100
	102350	PS / Glass	Black	35.00 x 10.00	34.30 x 9.30	13 Ø	1.33	3.00	-	+	5 / 100
	103350	PS / Glass	Black	35.00 x 10.00	34.30 x 9.30	20 Ø	3.14	3.00	-	+	5 / 100
	104350	PS / Glass	Clear	35.00 x 10.00	34.30 x 9.30	25 Ø	0.98	0.6	-	+	5 / 50
	200350	PS / Glass	Clear	35.00 x 10.00	34.30 x 9.30	13 Ø	1.33	3.00	+	+	5 / 50
	210350	PS / FLux	Clear	35.00 x 10.00	34.30 x 9.30	13 Ø	1.33	3.00	+	+	5 / 50
	211350	PS / FLux	Clear	35.00 x 10.00	34.30 x 9.30	20 Ø	3.14	3.00	+	+	5 / 50
	212350	PS / FLux	Black	35.00 x 10.00	34.30 x 9.30	13 Ø	1.33	3.00	+	+	5 / 50
	213350	PS / FLux	Black	35.00 x 10.00	34.30 x 9.30	20 Ø	3.14	3.00	+	+	5 / 50
	214350	PS / Flux	Clear	35.00 x 10.00	34.30 x 9.30	25 Ø	0.98	0.6	+	+	5 / 50
Confocal Plate											
	30106	PS / Glass	Clear	85.40 x 127.60	35.00 / well	13 Ø	1.33	3.00	-	+	1 / 4
	30206	PS / Glass	Clear	85.40 x 127.60	35.00 / well	20 Ø	3.14	3.00	-	+	1 / 4
	230106	PS / FLux	Clear	85.40 x 127.60	35.00 / well	13 Ø	1.33	3.00	+	+	1 / 4
	230206	PS / FLux	Clear	85.40 x 127.60	35.00 / well	20 Ø	3.14	3.00	+	+	1 / 4

Cell Culture

1-4. SPL3D™



Cells, cultured *in vitro* such as cell culture dish and flask, tend to show significantly different behaviors and reactions, compared to the *in vivo* culture. Therefore, *in vitro* studies most often do not fully correspond to the circumstances occurring around cells in a living organism, limiting deeper perception of cell biology. *In vivo* studies can be actualized through 3D cell culture, which is expected to resemble a closer biological environment.

- Spheroids improve the relevance of *in vitro* results.
- Spheroids serve as biological models of native tissues or engineered solutions.
- Spheroids are used as building blocks to form tissues.
- Spheroids in concert with other aggregated cell shapes allow for complex tissue architecture studies.

	Surfaces			Materials						
	Cell Culture Treated	Non-Treated	Low Binding Treatment	PS	PP	PET	HDPE	PTFE	PC	Nylon
Cell Floater		•	•	•						
Spheroid Forming Unit		•			•	•	•	•		
Spheroid Dish			•	•						
96well Hanging Drop Plate			•	•						
Multi Insert Dish			•	•					•	•

Cells in 3D culture

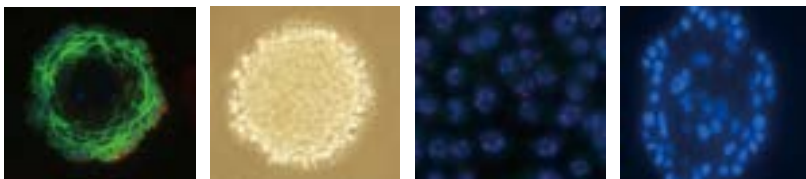

Cell Floater



SPL3D™ Cell Floater is a culture vessel that provides an optimized environment for 3D cell culture. The culture vessel, which is effective for the formation of spheroids of animal cells, does not require any special incubation techniques, and thus 3D cell culture can easily be implemented in the same way as conventional 2D culture.

Minimized cell attachment of SPL3D™ Cell Floater

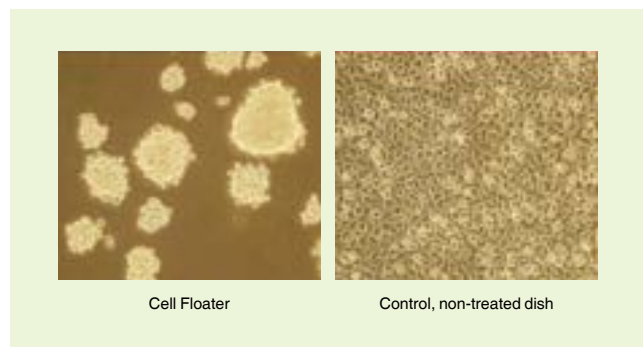
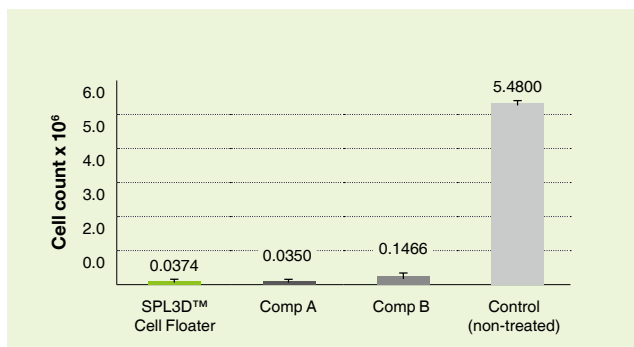



SPL3D™ Cell Floater showed a minimized cell attachment performance similar to that of the competitors.

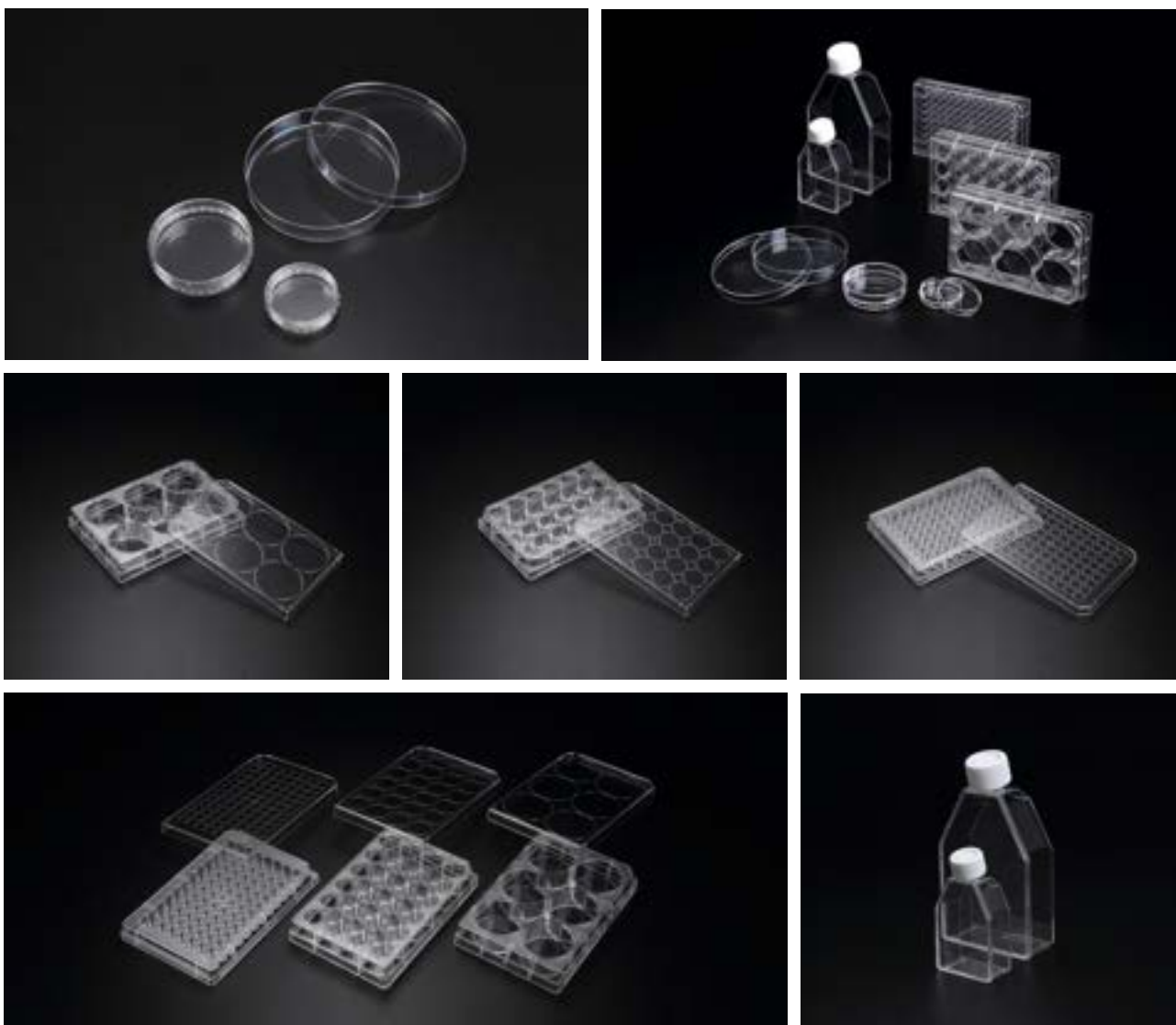



continued on next page





Cell Floater Dish

Type	Cat. No.	Material	Dish Style d x h (mm)	Internal Dimensions d x h (mm)	Growth Area (cm ²)	Working Vol. (ml)	External Grip	Packaging
	26035	PS	35.00 x 10.00	35.00 x 9.60	9.40	3.00	+	10 / 20
	26060	PS	60.00 x 15.00	52.80 x 12.80	21.50	5.00	+	10 / 20
	26100	PS	90.00 x 20.00	86.26 x 17.70	57.50	12.50	-	10 / 10

Cell Floater Plate

Type	Cat. No.	Material	Plate Type	External Dimensions w x l x h (mm)	Well Dimensions d x h (mm)	Growth Area (cm ²)	Working Vol. (ml)	Packaging
	39706	PS	6well	85.40 x 127.60 x 20.20	35.00 x 17.50	9.60	3.00	1 / 5
	39724	PS	24well	85.40 x 127.60 x 20.20	15.50 x 17.50	1.90	1.00	1 / 5
	39796	PS	96well Flat	85.40 x 127.60 x 14.40	6.50 x 10.80	0.33	0.20	1 / 5
	34896	PS	96well Round	85.40 x 127.60 x 14.40	6.50 x 11.00	0.66	0.20	1 / 5

Cell Floater Flask

Type	Cat. No.	Material	Cap Type	Growth Area (cm ²)	Working Vol. (ml)	Total Vol. (ml)	Packaging
	711025	PS	Filter	25.00	7.00	60.00	5 / 10
	711075	PS	Filter	75.00	25.00	250.00	1 / 3

Cell Culture

Spheroid Forming Unit

Spheroid Forming Unit is designed to allow stationary culture and rotary incubation of cell sheets or aggregates to assist generation of cell spheroids along with hanging drop method.

- Material (Frame): Polypropylene (PP)
- Material (Mesh): Polyethylene terephthalate (PET)
- Nominal membrane thickness: 68 μm
- Pore size: 65 μm
- Rotary incubation possible



Spheroid Forming Unit

Type	Cat. No.	Material (Tube / Cap / Filter / Dial / Mesh)	External Dimension d x h (mm)	Total Vol. (ml)	Pore Size (μm)	Sterile	Packaging
	911604	PC / HDPE / Acrylic copolymer / PP / PET	17.00 x 120.00	15.00	65.00	+	3 / 90

Spheroid Dish

SPL Spheroid Dish is designed for easy culture and counting the spheroid. Meshes inside the well facilitate identifying and counting the spheroids. After experiment, the spheroids can be easily collected.

- Mesh thickness: 137 μm
- Mesh pore size: 200 μm
- Non-treated for counting of spheroids
(Cat. No. 110350)
- Low Binding treatment for spheroid culture
(Cat. No. 111350)



continued on next page

**Spheroid Dish**

Type	Cat. No.	Material (Dish / Mesh)	Dish Style d x h (mm)	Internal Dimensions d x h (mm)	Working Vol. (ml)	Low Binding Treatment	Sterile	Packaging
	110350	PS / PE	35.00 x 10.00	13.00 x 1.00	0.20	-	+	3 / 15
	111350	PS / PE	35.00 x 10.00	25.00 x 1.00	0.80	+	+	3 / 15

Spheroid Forming Gel

Spheroid Forming Gel effectively helps the development of spheroid and it is suitable for 3D culture. Spheroid Forming Gel has advantages, it is easy to use and collect the cells, and the cells are uniform in size.

- Material: Hyaluronic acid
- Swelling size: 280 μm
- Total weight: 1 g (0.2 g / tube)

**Spheroid Forming Gel**

Type	Cat. No.	Material	Swelling size (μm)	Sterile	Packaging
	99005	Hyaluronic acid	280	+	5 tube / box

Cell Culture



96well Hanging Drop Plate

SPL Life Sciences provides 96well Hanging Drop Plate, suitable for spheroid culture. The shape of the holes is designed to position droplets safely. This shape keeps the droplets of the hanging drop consistent and stable culturing conditions. The reservoir prevents evaporation of the media, allowing for long-term culture. The tube extending into the well plate facilitates collect of spheroids.

- Physiological and non-expensive spheroid culture system
- Suitable for high-throughput screening (HTS)
- Suitable for long-term culture
- Non-pyrogenic
- Non-cytotoxic
- DNase / RNase-free
- Human DNA-free



96well Hanging Drop Plate

Type	Cat. No.	Material	External Dimensions w x l (mm)	Hole Depth (mm)	Droplet Vol. (µl)	Plate Type	Sterile	Packaging
	331096	PS	123.60 x 81.40	9.00	30.00	w/o Plate	+	1 / 10
	331196	PS	123.60 x 81.40	9.00	30.00	96well Cell Culture	+	1 / 5
	331296	PS	123.60 x 81.40	9.00	30.00	96well Cell Floater (Flat)	+	1 / 5

Multi Insert Dish

Multi Insert Dish is designed to study the interactions between different cell populations in a single dish, provided with 3 or 5 small inserts to allow multi-directional signal exchange but not transmigration.

- Material (Frame / Mesh): Polystyrene (PS) / Nylon
- Nominal membrane thickness: 10 ~ 23 µm
- Pore size: 23 µm
- 5 Inserts (24well size) (Cat. No. 911605, 911606, 911607, 911615, 911617, 911625, 911627)
- 3 Inserts (6well size) (Cat. No. 911107, 911117)
- Non-treated (Cat. No. 911605, 911606, 911607, 911107)
- Surface treated for attachment of cells (Cat. No. 911615, 911617, 911117)
- Low binding treated for spheroid culturing (Cat. No. 911625, 911627)
- Side mesh (Cat. No. 911605, 911615, 911625, 911607, 911617, 911627, 911107, 911117) available for signal exchanges between inserts
- Bottom mesh (Cat. No. 911606) available for signal exchange between inserts and bottom
- Groove bottom for magnetic stirrer positioning (Cat. No. 911607, 911617, 911627, 911107, 911117)



continued on next page



Cat. No. 911605



Cat. No. 911606



Cat. No. 911617



Cat. No. 911117

Multi Insert Dish

Type	Cat. No.	Insert Material	Dish Style d x h (mm)	Internal Dimensions d x h (mm)	Growth Area Per Insert (cm ²)	Working Vol. Per Dish (ml)	Groove Bottom	External Grip	Surface Treatment	Low binding Treatment	Sterile	Packaging
	911605	Nylon	60.00 x 20.00	52.80 x 18.00	1.77	15.00	-	+	-	-	+	9 / 18
	911606	PC	60.00 x 20.00	52.80 x 18.00	1.77	15.00	-	+	-	-	+	9 / 18
	911607	Nylon	60.00 x 20.00	49.53 x 19.30	1.77	15.00	+	+	-	-	+	9 / 18
	911615	Nylon	60.00 x 20.00	52.80 x 18.00	1.77	15.00	-	+	+	-	+	9 / 18
	911617	Nylon	60.00 x 20.00	49.53 x 19.30	1.77	15.00	+	+	+	-	+	9 / 18
	911625	Nylon	60.00 x 20.00	52.80 x 18.00	1.77	15.00	-	+	-	+	+	9 / 18
	911627	Nylon	60.00 x 20.00	49.53 x 19.30	1.77	15.00	+	+	-	+	+	9 / 18
	911107	Nylon	104.40 x 37.05	100.00 x 34.80	4.52	20.00	+	+	-	-	+	5 / 10
	911117	Nylon	104.40 x 37.05	100.00 x 34.80	4.52	20.00	+	+	+	-	+	5 / 10

Cell Culture

1-5. SPLInsert™

SPLInsert™ products closely mimic *in vivo* environment, providing improved attachment, growth, and differentiation of various cell types. With their permeable property, inserts are convenient and effective tools for diverse research areas, such as transportation and invasion studies. Specially selected track-etched membranes of three different pore sizes (0.4, 3.0 and 8.0 µm) are used for SPLInsert™ products. Track-etched membranes ensure precise pore size distribution and consistent pore density, providing well-controlled experimental parameters.

	Surfaces		Materials			
	Cell Culture Treated	Non-Treated	PS	PC	PET	Nylon
SPLInsert™ Hanging	•			•	•	
SPLInsert™ Standing	•			•	•	
Co-culture Disk (JLK)	•		•			•



SPLInsert™ Hanging : See 56p

Polycarbonate (PC): stain-free, low background interference

Polyethylene terephthalate (PET): retention of high chemical resistance and low protein binding property

Applicable experiments: invasion, migration, transportation, drug uptake, epithelial polarization, chemotaxis, co-culture, toxicity study, and *in vivo* barrier modeling

Optical Properties of Membranes

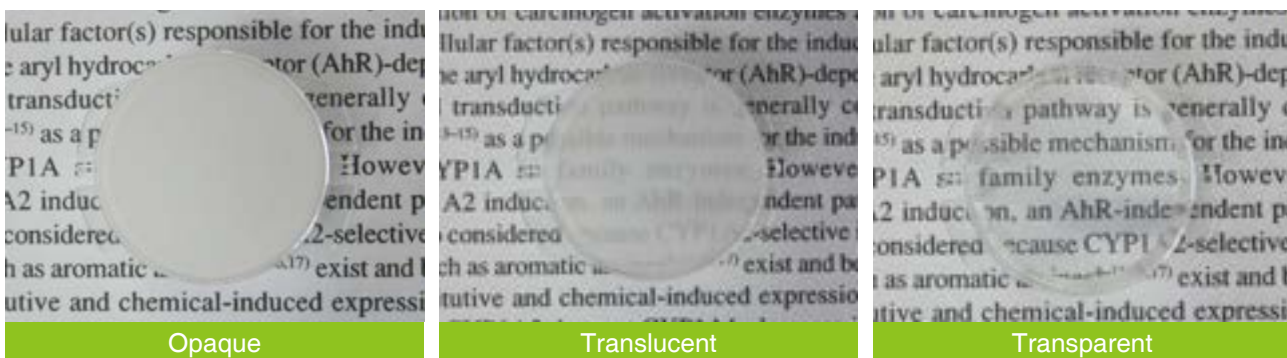

Opaque

Translucent

Transparent



Co-culture Dish (JLK)

Co-culture Dish (JLK) is designed to study the interactions between two different cell populations in a single dish, provided with an insert mesh to allow bi-directional signal exchange, achieving more *in vivo*-like environment.

- Material (Frame / Mesh): Polystyrene (PS) / Nylon
- Nominal membrane thickness: 10 - 23 μm
- Pore size: 23 μm
- Packed in cell culture-treated cell culture dishes (Cat. No. 20060, 20100)



Co-culture Dish (JLK)

Type	Cat. No.	Dish Style d x h (mm)	Internal Dimensions d x h (mm)	Growth Area (cm ²)	Working Vol. (ml)	External Grip	Surface Treatment	Sterile	Packaging
	209260	60.00 x 15.00	52.80 x 12.80	21.50	5.00	+	+	+	10 / 20
	209200	100.00 x 20.00	90.00 x 17.70	57.50	12.50	-	+	+	10 / 20

Cell Culture

SPLInsert™ Hanging









SPLInsert™ Hanging keeps a certain distance between the membrane and the well bottom to prevent potential damages during handling, suitable for co-culture and permeability assays.

- Distance from membrane to the bottom of the well:
6well Insert 1.2 mm, 12well Insert 1.2 mm, 24well Insert 1.3 mm
- Nominal membrane thickness: 10 - 23 μm
- Frame material: Polystyrene (Cat. No. 35xxx, 36xxx)
Polyethylene terephthalate (Cat. No. 37xxx)
- Packed in cell culture-treated cell culture plates
- Non-pyrogenic
- Non-cytotoxic
- DNase / RNase-free
- Human DNA-free



continued on next page

SPLInsert™ Hanging

Type	Cat. No.	Multiwell Plate Type	Membrane Material	Membrane Pore Size (µm)	Membrane Diameter (mm)	Growth Area (cm ²)	Working Vol. (ml)	Optical Properties	Sterile	Packaging
	35006	6well	PC	0.40	24.00	4.52	1.50 – 2.50	Opaque	+	6 Inserts / Plate 4 Plates / Box
	35106	6well	PC	3.00	24.00	4.52	1.50 – 2.50	Translucent	+	6 Inserts / Plate 4 Plates / Box
	35206	6well	PC	8.00	24.00	4.52	1.50 – 2.50	Translucent	+	6 Inserts / Plate 4 Plates / Box
	35012	12well	PC	0.40	10.50	0.90	0.40 – 1.00	Opaque	+	12 Inserts / Plate 4 Plates / Box
	35112	12well	PC	3.00	10.50	0.90	0.40 – 1.00	Translucent	+	12 Inserts / Plate 4 Plates / Box
	35212	12well	PC	8.00	10.50	0.90	0.40 – 1.00	Translucent	+	12 Inserts / Plate 4 Plates / Box
	35024	24well	PC	0.40	6.50	0.33	0.20 – 0.35	Opaque	+	12 Inserts / Plate 4 Plates / Box
	35124	24well	PC	3.00	6.50	0.33	0.20 – 0.35	Translucent	+	12 Inserts / Plate 4 Plates / Box
	35224	24well	PC	8.00	6.50	0.33	0.20 – 0.35	Translucent	+	12 Inserts/Plate 4 Plates/Box
	36006	6well	PET	0.40	24.00	4.52	1.50 – 2.50	Opaque	+	6 Inserts / Plate 4 Plates / Box
	36106	6well	PET	3.00	24.00	4.52	1.50 – 2.50	Translucent	+	6 Inserts / Plate 4 Plates / Box
	36206	6well	PET	8.00	24.00	4.52	1.50 – 2.50	Translucent	+	6 Inserts / Plate 4 Plates / Box
	36012	12well	PET	0.40	10.50	0.90	0.40 – 1.00	Opaque	+	12 Inserts / Plate 4 Plates / Box
	36112	12well	PET	3.00	10.50	0.90	0.40 – 1.00	Translucent	+	12 Inserts / Plate 4 Plates / Box
	36212	12well	PET	8.00	10.50	0.90	0.40 – 1.00	Translucent	+	12 Inserts / Plate 4 Plates / Box
	36024	24well	PET	0.40	6.50	0.33	0.20 – 0.35	Opaque	+	12 Inserts / Plate 4 Plates / Box
	36124	24well	PET	3.00	6.50	0.33	0.20 – 0.35	Translucent	+	12 Inserts / Plate 4 Plates / Box
	36224	24well	PET	8.00	6.50	0.33	0.20 – 0.35	Translucent	+	12 Inserts / Plate 4 Plates / Box
	37006	6well	PET	0.40	24.00	4.52	1.50 – 2.50	Transparent	+	6 Inserts / Plate 4 Plates / Box
	37106	6well	PET	3.00	24.00	4.52	1.50 – 2.50	Transparent	+	6 Inserts / Plate 4 Plates / Box
	37206	6well	PET	8.00	24.00	4.52	1.50 – 2.50	Transparent	+	6 Inserts / Plate 4 Plates / Box
	37012	12well	PET	0.40	10.50	0.90	0.40 – 1.00	Transparent	+	12 Inserts / Plate 4 Plates / Box
	37112	12well	PET	3.00	10.50	0.90	0.40 – 1.00	Transparent	+	12 Inserts / Plate 4 Plates / Box
	37212	12well	PET	8.00	10.50	0.90	0.40 – 1.00	Transparent	+	12 Inserts / Plate 4 Plates / Box
	37024	24well	PET	0.40	6.50	0.33	0.20 – 0.35	Transparent	+	12 Inserts / Plate 4 Plates / Box
	37124	24well	PET	3.00	6.50	0.33	0.20 – 0.35	Transparent	+	12 Inserts / Plate 4 Plates / Box
	37224	24well	PET	8.00	6.50	0.33	0.20 – 0.35	Transparent	+	12 Inserts / Plate 4 Plates / Box

Cell Culture

SPLInsert™ Standing

SPLInsert™ Standing is widely used for cell culture, for instance skin layer culture. The insert can be removed and transferred to other place for additional cell culture.

- Distance from membrane to the bottom of the well: 6well Insert 0.91 mm, 24well Insert 0.85 mm
- Nominal membrane thickness: 10 - 23 μm
- Frame material: Polystyrene (Cat. No. 35xxx, 36xxx)
Polyethylene terephthalate (Cat. No. 37xxx)
- Packed in cell culture-treated cell culture plates
- Non-pyrogenic
- Non-cytotoxic
- DNase / RNase-free
- Human DNA-free



continued on next page

SPLInsert™ Standing

Type	Cat. No.	Multiwell Plate Type	Membrane Material	Membrane Pore Size (µm)	Membrane Diameter (mm)	Growth Area (cm ²)	Working Vol. (ml)	Optical Properties	Sterile	Packaging
	35306	6well	PC	0.40	22.74	4.06	2.00 – 6.00	Opaque	+	6 Inserts / Plate 4 Plates / Box
	35406	6well	PC	3.00	22.74	4.06	2.00 – 6.00	Translucent	+	6 Inserts / Plate 4 Plates / Box
	35506	6well	PC	8.00	22.74	4.06	2.00 – 6.00	Translucent	+	6 Inserts / Plate 4 Plates / Box
	35324	24well	PC	0.40	8.75	0.60	0.20 – 0.60	Opaque	+	12 Inserts / Plate 4 Plates / Box
	35424	24well	PC	3.00	8.75	0.60	0.20 – 0.60	Translucent	+	12 Inserts/Plate 4 Plates/Box
	35524	24well	PC	8.00	8.75	0.60	0.20 – 0.60	Translucent	+	12 Inserts / Plate 4 Plates / Box
	36306	6well	PET	0.40	22.74	4.06	2.00 – 6.00	Opaque	+	6 Inserts / Plate 4 Plates / Box
	36406	6well	PET	3.00	22.74	4.06	2.00 – 6.00	Translucent	+	6 Inserts / Plate 4 Plates / Box
	36506	6well	PET	8.00	22.74	4.06	2.00 – 6.00	Translucent	+	6 Inserts / Plate 4 Plates / Box
	36324	24well	PET	0.40	8.75	0.60	0.20 – 0.60	Opaque	+	12 Inserts / Plate 4 Plates / Box
	36424	24well	PET	3.00	8.75	0.60	0.20 – 0.60	Translucent	+	12 Inserts / Plate 4 Plates / Box
	36524	24well	PET	8.00	8.75	0.60	0.20 – 0.60	Translucent	+	12 Inserts / Plate 4 Plates / Box
	37306	6well	PET	0.40	22.74	4.06	2.00 – 6.00	Transparent	+	6 Inserts / Plate 4 Plates / Box
	37406	6well	PET	3.00	22.74	4.06	2.00 – 6.00	Transparent	+	6 Inserts / Plate 4 Plates / Box
	37506	6well	PET	8.00	22.74	4.06	2.00 – 6.00	Transparent	+	6 Inserts / Plate 4 Plates / Box
	37324	24well	PET	0.40	8.75	0.60	0.20 – 0.60	Transparent	+	12 Inserts / Plate 4 Plates / Box
	37424	24well	PET	3.00	8.75	0.60	0.20 – 0.60	Transparent	+	12 Inserts / Plate 4 Plates / Box
	37524	24well	PET	8.00	8.75	0.60	0.20 – 0.60	Transparent	+	12 Inserts / Plate 4 Plates / Box

Cell Culture

1-6. SPLPermea™

SPL Life Sciences offers a next generation of culture ware made of high gas permeable material to meet the customer's needs.

In cell / tissue engineering research, flat plastic culturewares are commonly used for two-dimensional cell cultures. However, cell cultures on non-gas-permeable plastic culture wares and absence of medium flow may cause rapid exhaustion of dissolved oxygen and accumulation of carbon dioxide, giving extremely harmful stress to the cells. To overcome these issues, special containers utilizing gas permeable membrane were developed.

Gas-permeable membrane of culture ware allows rapid equilibration between partial pressures of oxygen in the atmosphere and those at the pericellular level. Because the diffusion gradients across gas permeable membranes are not steep, dissolved oxygen in culture wares is slightly less than atmospheric oxygen, while respired carbon dioxide rapidly diffuses away from the cells, preventing a drop in pH.

SPLPermea™ Dish

SPLPermea™ Dish, made of gas-permeable film with superior strength and clarity, ensures optimal gas exchange for effective cell culture. Due to its low water permeability, the culture medium is maintained for a long time without leakage or evaporation, while its conventional dish-type structure prevents ambient contamination. The SPLPermea™ Dish has low auto-fluorescence with high light transmission to enable applications in imaging and micro-reading.

- Gas-permeability tested (CO₂, O₂)
 - Leakage and evaporation tested
 - Transparent for microscopic observation and imaging
 - Low auto-fluorescence
 - High light transmission
 - Ergonomic design for easy handling and minimal contamination
- Non-pyrogenic
 - Non-cytotoxic
 - DNase / RNase-free
 - Human DNA-free



SPLPermea™ Dish

Type	Cat.No.	Material	Dish Style d x h (mm)	Internal Dimensions d x h (mm)	Growth Area (cm ²)	Working Vol. (ml)	External Grip	Surface Treatment	Sterile	Packaging
	200235	PS / Permea™ Film	44.88 x 12.65	35.12 x 11.20	9.40	3.00	+	-	+	5 / 50

SPLPermea™ Bag

The SPLPermea™ Bag made of the highest quality USP Class VI materials is a simple-to-use and single use device for cell culture. The unique design allows access to the culture in a closed system environment which reduces the possibility of contamination when compared to that of standard culturewares. The superior permeability to oxygen and carbon dioxide helps to maintain cell viability for a long time and improve cell expansion without the need for changing culture vessel. Additionally, water permeability is very low, so water loss is minimal. This next generation of cell culture bags can be used with greater fill volumes than classical standard cell culture devices, having minimal storage and disposal space in CO₂ incubator.

continued on next page

- Transparent for microscopic observation
- Compliant with USP guideline (USP class VI tested)
- Gas-permeability tested (CO₂, O₂)
- Leakage tested
- Manufactured from gas permeable polyethylene
- Individually packed
- Cap and needle-free valve with silicon septum
- Ergonomic design to facilitate easy handling and minimize contamination
- Cell growth area ranging from 110.5 ~ 325 cm²
- Available in 3 different culture volumes
- Culture bag racks are available (for 250 ml size of bag)
- Non-pyrogenic
- Non-cytotoxic
- DNase / RNase-free
- Human DNA-free



SPLPermea™ Bag

Type	Cat. No.	Material	Dimensions w x l (mm)	Working Vol. (ml)	Sterile	Packaging
	200110	Permea™ Film	162.00 x 115.00	100.00	+	15
	200125	Permea™ Film	223.00 x 146.00	250.00	+	10
	200150	Permea™ Film	254.00 x 154.00	500.00	+	5

SPLPermea™ Rack

SPLPermea™ Racks are useful for handling and storing of 250 ml SPLPermea™ bag.

- For handling and storing of SPLPermea™ Bag
- Colors: Natural

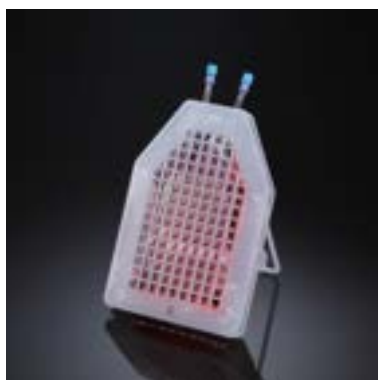

SPLPermea™ Rack

Type	Cat.No.	Material	Dimensions w x l (mm)	Sterile	Packaging
	200425	PP	234.99 x 155.84	-	5

Cell Culture

1-7. SPLScar™

SPLScar™ Products are designed for a wide range of cell studies, including cell migration, wound healing, and cancer metastasis, providing highly uniform and reproducible conditions to enhance the quality of your experiment.









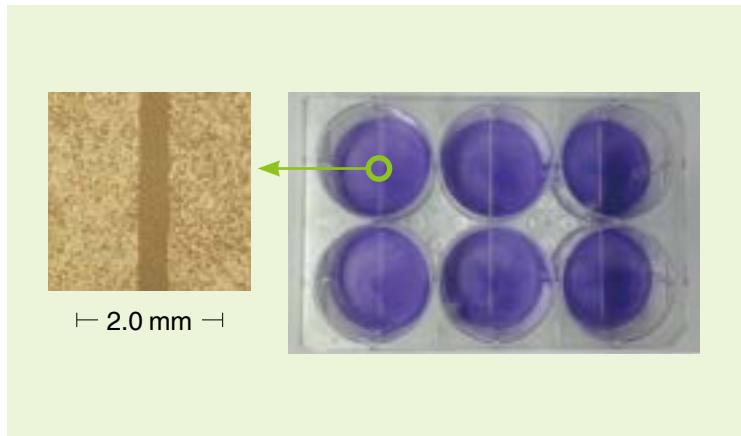
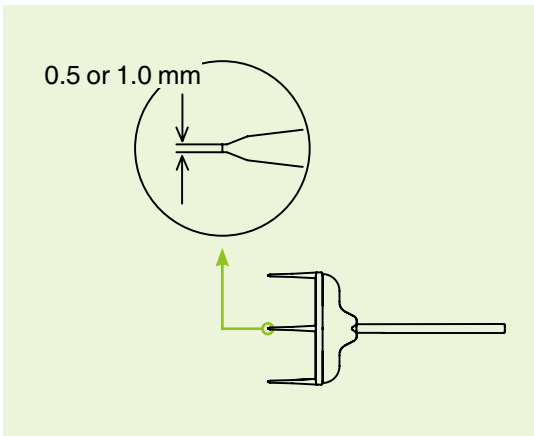

SPLScar™ Scratcher

SPLScar™ Scratcher ensures the uniformity and reproducibility of the possible products used in cancer metastasis, wound healing, and cell migration research. SPLScar™ Scratcher consists of a lid with identical holes and a scratcher, suitable for use in 6well or 24well configurations

- Scratcher tip width: 0.5 mm or 1.0 mm → allowing a full view of the wound width in a single frame under high-magnifications
- 1 scratcher tip & 1 line lid / pack
- Non-pyrogenic
- Non-cytotoxic
- DNase / RNase-free
- Human DNA-free



SPLScar™ Scratcher

Type	Cat. No.	Lid Type	Material (Scratcher / Lid)	Tip Width (mm)	Sterile	Packaging
 	201906	6well	HDPE / PS	0.50	+	1 / 20
 	201924	24well	HDPE / PS	0.50	+	1 / 20
 	201907	6well	HDPE / PS	1.00	+	1 / 20
 	201925	24well	HDPE / PS	1.00	+	1 / 20





SPLScar™ Block

SPLScar™ Block is easily attachable to surface, and thus is applicable to a variety of products for studying cell migration, wound healing, and metastasis of cancer cell. Block is composed of 500 µm-thick-wall to artificially generate cell free gap(s), ensuring higher uniformity and reproducibility.

- Cell Culture Dish (Cat. No. 201935, 201938)
 - Confocal Dish (Cat. No. 201936, 201939 - Glass / Cat.No. 201937, 201930 - FLux)
 - Confocal Plate (Cat. No. 201916)
 - Cell Culture Slide (Cat. No. 201904 - Glass / Cat. No. 201914 - DLux / Cat. No. 201934 - FLux)
 - Individual packaged (Cat. No. 201902 - 2well / Cat. No. 201903 - 3well)
- Non-pyrogenic
 - Non-cytotoxic
 - DNase / RNase-free
 - Human DNA-free



SPLScar™ Block

Type	Cat. No.	Product Type	Bottom Type	Size	Block Well Type	Surface Treatment	Sterile	Packaging
	201935	Cell Culture Dish	PS	35 Ø	2	+	+	1 / dish, total 30
	201938	Cell Culture Dish	PS	35 Ø	3	+	+	1 / dish, total 30
	201936	Confocal Dish	Glass	35 Ø	2	+	+	1 / dish, total 30
	201937	Confocal Dish	FLux	35 Ø	2	+	+	1 / dish, total 30
	201939	Confocal Dish	Glass	35 Ø	3	+	+	1 / dish, total 30
	201930	Confocal Dish	FLux	35 Ø	3	+	+	1 / dish, total 30
	201916	Confocal Plate	Glass	6well	2	-	+	6 / plate, total 18
	201904	Cell Culture Slide	Glass	4well	3	-	+	4 / slide, total 24
	201914	Cell Culture Slide	DLux	4well	3	+	+	4 / slide, total 24
	201934	Cell Culture Slide	FLux	4well	3	+	+	4 / slide, total 24
	201902	Individual	-	-	2	-	+	total 25
	201903	Individual	-	-	3	-	+	total 25

Cell Culture

1-8. *In vitro* Fertilization

SPL IVF Products are designed for application for treatment in obstetrics / gynecology and specific cell culture research, such as human embryonic cell culture.

SPL IVF Products provide optimized surface for culturing embryonic cells and maintaining their morphology and specific functions.

It is recommended that cells cultured in SPL Life Sciences IVF Products are maintained in appropriate culture medium and culture grade chemicals.

	Surfaces		Materials
	Cell Culture Treated	Non-Treated	PS
Cell Culture Plate 4well	•	•	•
IVF Culture Dish	•	•	•

Cell Culture Plate 4well

- Designed to prevent cross contamination
- Effective gas exchange lid inner design
- Alphanumeric labeling
- Compliant with USP guideline (USP class VI tested)
- Compliant with ANSI guideline
- Mouse Embryo Assay (MEA) test passed

- Non-pyrogenic
- Non-cytotoxic
- Non-genotoxic
- Non-mutagenic
- DNase / RNase-free
- Human DNA-free



Cell Culture Plate 4well

Type	Cat. No.	Material	External Dimensions d x h (mm)	Well Dimension (mm)	Growth Area (cm ²)	Working Vol. (ml)	Surface Treatment	Sterile	Packaging
	30004	PS	66.00 x 66.00	15.80	2.00	1.00	+	+	4 / 120
	32004	PS	66.00 x 66.00	15.80	2.00	1.00	-	+	4 / 120

IVF Dish



SPL Life Sciences provides IVF Culture Dishes for *in vitro* fertilization researches.

- Center well type (Cat. No. 20260, 20261)
- External grip for handling
- Compliant with USP guideline (USP class VI tested)
- Compliant with ANSI guideline
- Mouse Embryo Assay (MEA) Test passed

- Non-pyrogenic
- Non-cytotoxic
- Non-genotoxic
- Non-mutagenic
- DNase / RNase-free
- Human DNA-free



IVF Culture Dish

Type	Cat. No.	Material	External Dimensions d x h (mm)	Internal Dimension (mm)	Surface Treatment	Sterile	Packaging
	20260	PS	60.00 x 15.00	20.00	+	+	10 / 500
	20261	PS	60.00 x 15.00	20.00	-	+	10 / 500
	20262	PS	60.00 x 15.00	-	+	+	10 / 500
	20263	PS	60.00 x 15.00	-	-	+	10 / 500

Cell Culture

1-9. Cryopreservation

Cryovial

SPL Cryopreservation products are store cells, tissues, specimens, microbiological samples, nucleic acid, and protein samples in extreme temperatures ranging from -196°C to 60°C.

- Use only in vapor-phased liquid nitrogen
- Distinctive external & Internal cap design
- External cap: External thread of the body fits perfectly into internal thread of the cap in helical form
- Internal cap: Internal thread of the body fits perfectly into the external thread of the cap in helical form
- Self-standing bottom
- Packed in re-closeable zip-lock pack
- Without Silicone washer (Cat. No. 43012)
- Vial Cap Insert: Available in 5 colors (Cat. No. 43032)
- Recommended volume for cryopreservation (Cat. No. 43113, 43023): 4.50 ml
- Non-pyrogenic
- Non-cytotoxic
- DNase / RNase-free
- Human DNA-free



continued on next page

Cryovial

Type	Cat. No.	Material (Tube / Cap)	Cap Type	Bottom Type	Color	Total Vol. (ml)	External Dimensions d x h (mm)	Washer	Sterile	Packaging
	43111	PP / HDPE	External	Conical	Clear	1.20	13.10 x 42.50	+	+	50 / 500
	43021	PP / PP	Internal	Conical	Clear	1.20	13.10 x 42.50	+	+	50 / 500
	43012	PP / HDPE	External	Round	Clear	1.80	13.10 x 45.50	-	+	50 / 500
	43112	PP / HDPE	External	Round	Clear	1.80	13.10 x 47.80	+	+	50 / 500
	43022	PP / PP	Internal	Round	Clear	1.80	13.10 x 49.70	+	+	50 / 500
	43113	PP / HDPE	External	Round	Clear	5.00	13.10 x 92.00	+	+	50 / 500
	43023	PP / PP	Internal	Round	Clear	5.00	13.10 x 92.00	+	+	50 / 500
	44112	PP / HDPE	External	Round	Amber	1.80	13.10 x 47.80	+	+	50 / 500
	44022	PP / PP	Internal	Round	Amber	1.80	13.10 x 49.70	+	+	50 / 500
	43032	PP	Cap Insert	-	5 color	-	10.40	-	-	100 / 500

Cryo Tissue Container

SPL Life Sciences provides vessels for cryogenic storage of tissue samples. Cryo Tissue Container is suitable for use in -80°C deep freezer or in the vapor-phased liquid nitrogen up to -178°C. The stackable block-shaped structure is convenient for storing and transporting samples.

- Use only in vapor-phased liquid nitrogen
- Stackable feature
- Two marking area on outside

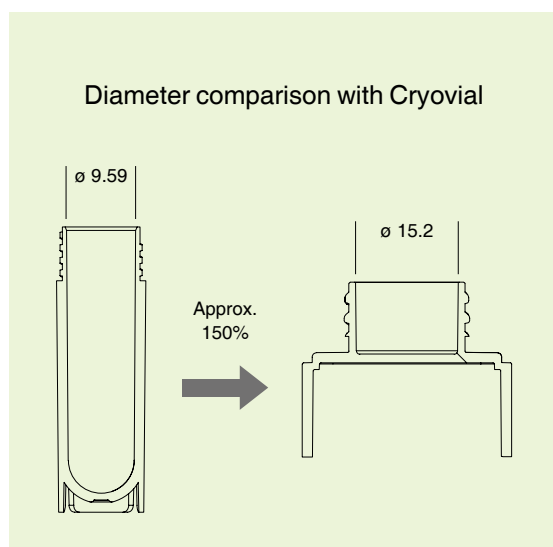
**Cryo Tissue Container**

Type	Cat. No.	Material (Cap / Body)	External Dimensions w x l x h (mm)	Internal Dimensions d x h (mm)	Total Vol. (ml)	Sterile	Packaging
	43014	HDPE / PP	30.00 x 30.00 x 27.20	15.20 x 10.70	1.50	+	50 / 100

Cell Culture



Cryo Box

Cryo Boxes are useful for storing vials in ultra low temperature environments.

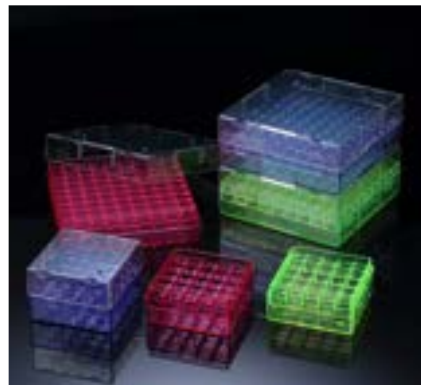
- For storing of microcentrifuge tubes or cryovials
- Designed for enhanced drainage of liquid nitrogen
- Alphanumeric indications for sample location
- Temperature range: -196°C to 121°C (Cat. No. 80025, 80081, 80281)
- 3 colors: Blue, Pink, Green (Cat. No. 80025, 80081, 80281)
- Cardboard Box: Moisture repellent coating (Cat. No. 80181)
- 1.2 ml / 1.8 ml Cryovials are available (Cat. No. 80025, 80081, 80181)
- 5 ml Cryovial use only (Cat. No. 80281)



Cryo Box

Type	Cat. No.	Material	Feature	Description	Packaging
	80025	PC	3 Colors	5 x 5 (25 Holes)	1 / 20
	80081	PC	3 Colors	9 x 9 (81 Holes)	1 / 10
	80281	PC	3 Colors	9 x 9 (81 Holes)	1 / 6
	80181	Cardboard	-	9 x 9 (81 Holes)	40

Cryovial Rack

SPL Cryovial Racks are designed for handling and storage of Cryovials.

- Numeric labeling
- 3 colors: Blue, Green, Red
- Autoclavable

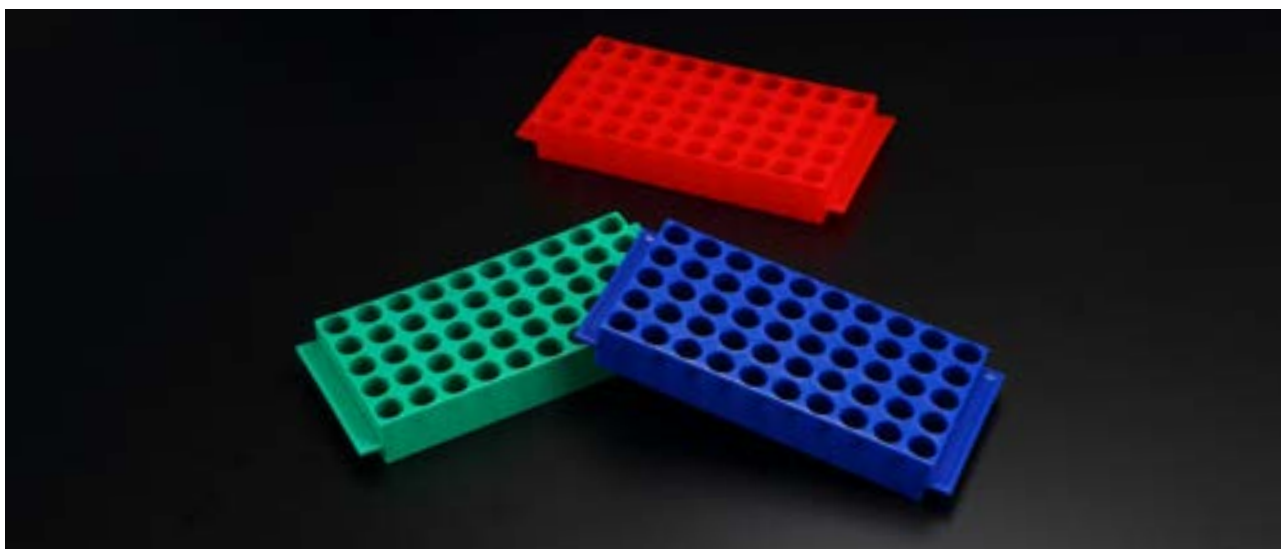

Cryovial Rack

Type	Cat. No.	Material	Feature	Description	Packaging
	61050	PP	3 Colors	5 x 10 (50 Holes)	10

Cell Culture

1-10. SPLFlow™

SPLFlow™



SPLFlow™ is designed for adherent cell culture under flow conditions. SPLFlow™ enables shear stress analysis by controlling the flow rate and exhibits high-resolution real-time microscopy of living cells and fixed cells.

SPL Life Sciences provides two types: SPLFlow™ Straight (Cat. No. 202501) and Gradient (Cat. No. 202502). Straight type is suitable for large area of uniform shear stress analysis. Gradient type is a special channel design intended to observe linear shear stress in a flow field.

- Channel thickness: 500 µm
- Working volume: 150 µl
- Non-pyrogenic
- Non-cytotoxic
- DNase / RNase-free
- Human DNA-free



SPLFlow™

Type	Cat. No.	Material (Outer / Bottom)	Dimensions w x l (mm)	Growth Area (cm ²)	Working Vol. (µl)	Sterile	Packaging
	202501	DLux / FLux	25.00 x 75.00	2.09	150.00	+	1 / 10
	202502	DLux / FLux	25.00 x 75.00	3.15	150.00	+	1 / 10



Cell Scraper : See page 74

Cell Culture

1-11. Accessories



SPL Life Sciences provides various accessories for cell culture.

Cell Strainer

Cell Strainers of SPL Life Sciences are ideal for obtaining uniform single cell suspension from various sources. Cell Strainers are made of nylon with 3 different pore size meshes, showing optimal performances in a variety of applications such as stem cell and primary cell preparation.



Cell Strainer

Type	Cat. No.	Material (Frame / Mesh)	Color	Pore Size (μm)	Sterile	Packaging
	93040	PP / Nylon	Blue	40.00	+	1 / 50
	93070	PP / Nylon	Clear	70.00	+	1 / 50
	93100	PP / Nylon	Yellow	100.00	+	1 / 50

Multi C-Strainer

Multi Cell Strainer (C-Strainer) is used for rapid cell separation from the primary tissue or cell mass. The Multi C-Strainer is the most flexible small cell strainer fitting on a wide range of tubes, e.g. 1.5 ml Microcentrifuge Tubes (Cat. No. 60015), Test Tubes (Cat. No. 40005), 5 ml Tubes (Cat. No. 50005, 51005), 15 ml Conical Tubes (Cat. No. 50015). Its unique design allows avoiding overflow and helps speedy filtration.



Multi C-Strainer

Type	Cat. No.	Material (Frame / Mesh)	Color	Pore Size (µm)	Sterile	Packaging
	94020	PP / Nylon	Green	20.00	+	1 / 50
	94030	PP / Nylon	Orange	30.00	+	1 / 50
	94040	PP / Nylon	Blue	40.00	+	1 / 50
	94070	PP / Nylon	Clear	70.00	+	1 / 50
	94100	PP / Nylon	Yellow	100.00	+	1 / 50

Cell Culture

Cell Lifter

Cell Lifters are specially designed for easy scraping of attached cells on culture dish & plate surfaces. Individual packing eliminates possible chances of contamination during cell culture.

- Ideal for the manual harvesting of cells
- Two blade types on a single handle
- Wide blade types are ideal for dish and 6well plates
- Non-pyrogenic
- Non-cytotoxic
- DNase / RNase-free
- Human DNA-free



Cell Lifter

Type	Cat. No.	Material	Length (mm)	Blade Width (mm)	Sterile	Packaging
	90040	PP	218.00	23.00 / 12.00	+	1 / 100



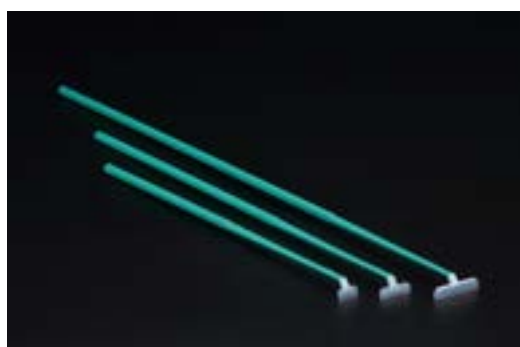

Cell Scraper

Cell Scrapers are designed to facilitate the collection of attached cells on culture dishes, flasks, or plates. Sterilization and individual packing eliminate possible chances of contamination during cell culture and scraper handling.

- Ideal for the manual harvesting of cells
- Soft blade, made of LDPE, for gentle collection of cells without damages
- Available in 3 different width types: 13 mm / 20 mm / 30 mm
- Non-pyrogenic
- Non-cytotoxic
- DNase / RNase-free
- Human DNA-free

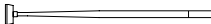

Cell Scraper

Type	Cat. No.	Material (Handle / Blade)	Length (mm)	Blade Width (mm)	Sterile	Packaging
	90020	PS / LDPE	237.00	13.00	+	1 / 100
	90021	PS / LDPE	237.00	13.00	+	1 / 100
	90030	PS / LDPE	290.00	20.00	+	1 / 100
	90031	PS / LDPE	290.00	20.00	+	1 / 100
	90032	PS / LDPE	399.10	30.00	+	1 / 100

Strainer Tube

The Strainer Tube consists of a 35 µm Nylon Mesh Cap, which makes it easy to separate cells from tissue. It is easy to prepare samples for FACS analysis.

- Internal graduations
- Dual-position snap cap for easy handling
- Sterile
- Non-pyrogenic
- Non-cytotoxic
- DNase / RNase-free
- Human DNA-free

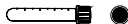

Strainer Tube

Type	Cat. No.	Material (Tube / Cap)	Pore Size (µm)	Dimensions d x h (mm)	Total Vol. (ml)	RCF Rating	Sterile	Packaging
	40405	PS / LDPE	35.00	12.00 x 75.00	5.00	1,400 x g	+	25 / 100

Cloning Cylinder



Cloning Cylinder facilitates the separation of cell clones generated from single cells, making it easy to obtain uniform cells.



- Sterile
- Non-pyrogenic
- Non-cytotoxic
- DNase / RNase-free
- Human DNA-free



Cloning Cylinder

Type	Cat. No.	Material	Size	Dimensions (mm)	Sterile	Packaging
	90070	PS	Small	7.70 x 8.00	+	10 / 50
	90071	PS	Medium	9.20 x 8.00	+	10 / 50
	90072	PS	Large	13.00 x 11.00	+	10 / 50

Molecular Analysis

SPL provides reliable and high-quality products to make molecular analyses more convenient and efficient. With the advancement of technology, more studies were conducted to explain the phenomena of life through molecular analysis.

SPL Life Sciences provides reliable and high-quality products to make molecular analyses more convenient and efficient and ultimately enable scientists to understand the fundamentals of molecular biology.

One of the most common molecular analysis methods is immunoassay; SPL microplates are available with a wide range of options that includes surface, color, bottom and well types, and PCR tubes for applications in polymerase chain reaction (PCR).

2-1. Immunoassay 78

Immunoplate.....	79
Immunoplate Strip.....	79
Immunoplate Strip Single Well.....	80
Black & White Immunoplate.....	80
B & W Immunoplate Strip.....	81
384 HT Plate.....	82
Miniwell Tray.....	82
Immunotube.....	83

2-2. Molecular Biology 84

PCR Tube.....	84
PCR Plate.....	85
Filter Tube.....	86
Vacuum Filter Tube.....	87
Dialysis Chamber.....	88
Gel Extractor.....	89
Blood Separation Tube.....	89
Cuvette.....	90
UVMax™.....	91
Bottle Top Filter.....	92
Bottle Top Filter Unit.....	93
Spin Column.....	93

2-3. SPLPro-Crystal™ 94

SPLPro-Crystal™ Plate	94
SPLPro-Crystal™ Coverslip	95

2-4. Accessories 96

SPL SEAL™	96
SPL SEAL™ Pressure-sensitive Tape	96
SPL SEAL™ Aluminum Tape	97
SPL Lid	97

Molecular Analysis

2-1. Immunoassay

Immunoassay is a standardized technique for detecting biomolecules with high specificity and sensitivity based on the antigen-antibody binding. SPL provides four different surface hydrophobicities to respond to different biomolecules. SPL's immunoassay microplates are manufactured from optically clear virgin polystyrene, ideal for all immunosorbent assays.

SPL Life Sciences manufactures microplates for diagnostics and immunological researches.

SPL provides researchers with a variety of microplates specifically designed for immunoassay:

Homogeneity

SPL provides immunoplates in standardized form, applicable to almost all laboratory ELISA equipment, to produce consistent results between wells or plates, regardless of the date of manufacture.

Color types

Three different colored plates are available with specific functions. While transparent clear plates are suitable for colorimetric assays, white and black plates are ideal for fluorescence and luminescence assays.

White plates ensure maximum reflection and minimum cross-talk, appropriate for luminescence assay. Black plates ensure minimum light scattering and cross-talk during fluorescence assay.

Bottom types

Flat well bottom has excellent optical transmission and low background absorbance. Round well bottom allows easy mixing and washing

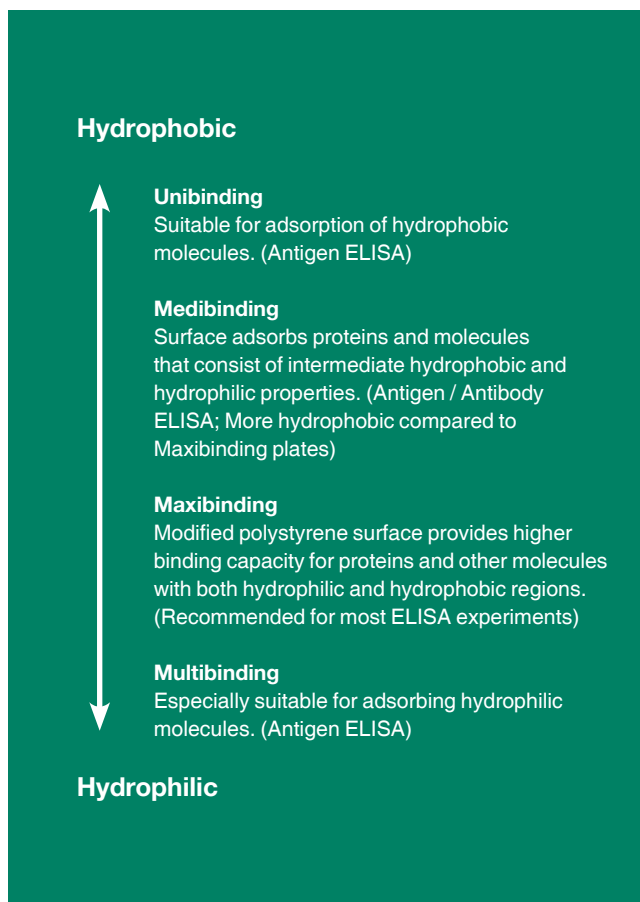



Immunoplate

- Plate type (96well plate)
- Lid not included
- 2 types bottom: Flat or Round
- Developed for immunoassay (ELISA) and general binding assay
- Uniform surface homogeneity
- Raised rims on the wells
- Alphanumeric labeling
- Designed for easy handling and automation



Immunoplate

Type	Cat. No.	Material	Bottom Type	Surface Type	External Dimensions w x l x h (mm)	Bottom Surface Area (cm ²)	Total Vol. (μl)	Working Vol. (μl)	Packaging
	32296	PS	Flat	Maxibinding	85.40 x 127.60 x 14.40	0.33	300.00	200.00	10 / 100
	32396	PS	Flat	Medibinding	85.40 x 127.60 x 14.40	0.33	300.00	200.00	10 / 100
	32496	PS	Flat	Unibinding	85.40 x 127.60 x 14.40	0.33	300.00	200.00	10 / 100
	32596	PS	Flat	Multibinding	85.40 x 127.60 x 14.40	0.33	300.00	200.00	10 / 100
	32696	PS	Round	Maxibinding	85.40 x 127.60 x 14.40	0.66	300.00	200.00	10 / 100
	32796	PS	Round	Unibinding	85.40 x 127.60 x 14.40	0.66	300.00	200.00	10 / 100

Immunoplate Strip

- 8well strip type
- Lid not included
- Developed for immunoassay (ELISA) and general binding assay
- Flat bottom
- Uniform surface homogeneity
- Raised rims on the wells
- Alphanumeric labeling
- Designed for easy handling and automation



Immunoplate Strip

Type	Cat. No.	Material	Surface Type	External Dimensions w x l x h (mm)	Bottom Surface Area (cm ²)	Total Vol. (μl)	Working Vol. (μl)	Packaging
	38096	PS	Maxibinding	85.40 x 127.60 x 14.40	0.33	300.00	200.00	10 / 100
	38196	PS	Medibinding	85.40 x 127.60 x 14.40	0.33	300.00	200.00	10 / 100
	38496	PS	Unibinding	85.40 x 127.60 x 14.40	0.33	300.00	200.00	10 / 100
	38596	PS	Multibinding	85.40 x 127.60 x 14.40	0.33	300.00	200.00	10 / 100

Molecular Analysis

Immunoplate Strip Single Well

- Strip single well type (8well / strip, breakable well)
- Lid not included
- Developed for immunoassay (ELISA) and general binding assay
- Uniform surface homogeneity
- Flat bottom
- Raised rims on the wells
- Alphanumeric labeling
- Designed for easy handling and automation



Immunoplate Strip Single Well

Type	Cat. No.	Material	Surface Type	External Dimensions w x l x h (mm)	Bottom Surface Area (cm ²)	Total Vol. (μl)	Working Vol. (μl)	Packaging
	38296	PS	Maxibinding	85.40 x 127.60 x 14.40	0.33	300.00	200.00	10 / 100
	38396	PS	Medibinding	85.40 x 127.60 x 14.40	0.33	300.00	200.00	10 / 100
	38696	PS	Unibinding	85.40 x 127.60 x 14.40	0.33	300.00	200.00	10 / 100
	38796	PS	Multibinding	85.40 x 127.60 x 14.40	0.33	300.00	200.00	10 / 100





Black & White Immunoplate

SPL provides high-quality 96well plates suitable for various high throughput assays. Fluorescence and luminescence assays have been successfully tested with SPL 96well microplates by many high throughput laboratories. SPL 96well microplates have a characteristic feature of high signal with low background.

- White plates provide maximum reflection and minimum cross-talk for luminescence assay.
- Black plates are designed for minimum light scattering and cross-talk during fluorescence assay.
- Suitable for fluorescence assay, luminescence assay
- 2 surface types
- Individual lids provided for each plate (Black plate with black lid, White plate with transparent lid)
- Plate type (96well plate)
- HTS (High-Throughput Screening) compatible
- Flat bottom
- Raised rims on the wells
- Alphanumeric labeling
- Designed for easy handling and automation



Black & White Immunoplate

Type	Cat. No.	Material	Plate Color	Surface Type	External Dimensions w x l x h (mm)	Bottom Surface Area (cm ²)	Total Vol. (μl)	Working Vol. (μl)	Packaging
	31396	PS	White	Maxibinding	85.40 x 127.60 x 14.40	0.33	300.00	200.00	10 / 100
	31496	PS	Black	Maxibinding	85.40 x 127.60 x 14.40	0.33	300.00	200.00	10 / 100
	31196	PS	White	Unibinding	85.40 x 127.60 x 14.40	0.33	300.00	200.00	10 / 100
	31296	PS	Black	Unibinding	85.40 x 127.60 x 14.40	0.33	300.00	200.00	10 / 100





B & W Immunoplate Strip

SPL Life Sciences provides high-quality luminescence assays. Successful testing of SPL products have been performed in many research laboratories, with results featuring high signal with low background.

- White plates provide maximum reflection and minimum cross-talk for luminescence assay.
- Black plates are designed for minimum light scattering and cross-talk during fluorescence assay.
- Suitable for fluorescence and luminescence assays
- 2 surface types
- 8well strip type
- Lid not included
- Flat bottom
- Raised rims on the wells
- Alphanumeric labeling
- Designed for easy handling and automation



B & W Immunoplate Strip

Type	Cat. No.	Material	Well Color	Surface Type	External Dimensions w x l x h (mm)	Bottom Surface Area (cm ²)	Total Vol. (μl)	Working Vol. (μl)	Packaging
	31796	PS	White	Maxibinding	85.40 x 127.60 x 14.40	0.33	300.00	200.00	10 / 100
	31896	PS	Black	Maxibinding	85.40 x 127.60 x 14.40	0.33	300.00	200.00	10 / 100
	31596	PS	White	Unibinding	85.40 x 127.60 x 14.40	0.33	300.00	200.00	10 / 100
	31696	PS	Black	Unibinding	85.40 x 127.60 x 14.40	0.33	300.00	200.00	10 / 100

Molecular Analysis







384 HT Plate

SPL Life Sciences provides high-quality 384 HT Plates for high throughput research laboratories. Fluorescent and luminescent assays have been successfully tested with SPL 384 HT Plates, with results featuring high signal with low background.

- White plates provide maximum reflection and minimum cross-talk for luminescence assay.
- Black plates are designed for minimum light scattering and cross-talk during fluorescence assay.
- Suitable for colorimetry, fluorescence and luminescence assays
- HTS (High-Throughput Screening) compatible
- Transparent lid provided with each well plate
- Flat bottom
- Alphanumeric labeling
- 2 surface types



384 HT Plate

Type	Cat. No.	Material	Plate Color	Surface Type	External Dimensions w x l x h (mm)	Bottom Surface Area (cm ²)	Total Vol. (μl)	Working Vol. (μl)	Packaging
	34384	PS	Clear	Maxibinding	85.40 x 127.60 x 14.40	0.07	120.00	100.00	10 / 40
	35384	PS	White	Maxibinding	85.40 x 127.60 x 14.40	0.07	120.00	100.00	10 / 40
	36384	PS	Black	Maxibinding	85.40 x 127.60 x 14.40	0.07	120.00	100.00	10 / 40
	31384	PS	Clear	Unibinding	85.40 x 127.60 x 14.40	0.07	120.00	100.00	10 / 40
	32384	PS	White	Unibinding	85.40 x 127.60 x 14.40	0.07	120.00	100.00	10 / 40
	33384	PS	Black	Unibinding	85.40 x 127.60 x 14.40	0.07	120.00	100.00	10 / 40

Miniwell Tray

Miniwell Trays are used in a broad spectrum of applications, including cloning experiments, sample incubations, and in tissue culture based analytical systems. The crystallisation drop is localized centrally as a result of the conical well geometry, and the flat bottom makes for optimal monitoring.





continued on next page

- Terasaki format plate
- Stackable
- Virgin, high clarity polystyrene (Excellent optical)
- Surface treatment and Sterilized (Cat. No. 30060, 30072)

- Non-pyrogenic
- Non-cytotoxic
- DNase / RNase-free
- Human DNA-free

Miniwell Tray

Type	Cat. No.	Well Type	Material	External Dimension w x l (mm)	Working vol. (µl)	Surface Treatment	Sterile	Packaging
	30060	60	PS	83.00 x 58.00	10.00	+	+	10 / 100
	31060	60	PS	83.00 x 58.00	10.00	-	-	10 / 100
	30072	72	PS	83.00 x 58.00	10.00	+	+	10 / 100
	31072	72	PS	83.00 x 58.00	10.00	-	-	10 / 100

Immunotube

SPL Life Sciences provides Immunotubes for diagnostic and immunological purposes.

- 2 surface types
- For immunoassay (ELISA, RIA)
- High optical quality

Hydrophobic

↑

Unibinding
Suitable for adsorption of hydrophobic molecules.
(Antigen ELISA)

Maxibinding
Modified polystyrene surface for higher binding capacity for proteins and other molecules with both hydrophilic and hydrophobic regions.
(Recommended for most ELISA experiments)

↓

Hydrophilic

PP : With high chemical resistance, it withstands acids and bases at room temperature and is hardness



PS : Commonly used and transparent. Withstands weak acids and bases.



Immunotube

Type	Cat. No.	Material	Surface Type	External Dimensions d x h (mm)	Total Vol. (ml)	Packaging
	43005	PS	Unibinding	12.00 x 75.00	5.00	250 / 2,000
	43015	PS	Maxibinding	12.00 x 75.00	5.00	250 / 2,000
	43055	PP	Unibinding	12.00 x 75.00	5.00	50 / 500

Molecular Analysis

2-2. Molecular Biology

PCR Tube

SPL provides 0.2 ml PCR Tube in a standardized form, applicable to almost all laboratory PCR equipment. The wall of the PCR Tube is designed relatively thin to optimally conduct heat to the reaction solution. The tight sealing between the tube body and its cap ensures minimal evaporation and prevents sample leakages. The cap is provided in 2 different forms, flat and dome. Flat type is useful when labeling is required, while dome type prevents the reaction solution from binding to the cap surface. SPL provides single PCR Tube with a cap attached, and strip tubes, composed of 8 bodies and 8 caps connected horizontally. and strip PCR Tube with the attached cap.

- Designed to prevent contamination
- Designed for effective thermal conductivity
- Smooth opening and tight sealing
- 2 tube types: Single / Strip
- 4 cap types: Attached Flat / Attached Dome / Strip Flat / Strip Dome
- Separately packaged bodies and caps (Cat. No. 60008, 60018, 60028)
- Non-pyrogenic
- Non-cytotoxic
- DNase / RNase-free
- Human DNA-free



PCR Tube

Type	Cat. No.	Material	Color	Cap Type	Tube Type	Total Vol. (ml)	Sterile	Packaging
	60001	PP	Clear	Flat	Single	0.20	-	500 / 1,000
	60008	PP	Clear	Flat (Strip)	Strip	0.20	-	120 / 120
	60028	PP	White	Flat (Strip)	Strip	0.20	-	120 / 120
	60048	PP	Clear	Flat (Attached)	Strip	0.20	-	120 / 120
	60011	PP	Clear	Dome	Single	0.20	-	500 / 1,000
	60018	PP	Clear	Dome (Strip)	Strip	0.20	-	120 / 120



PCR Plate

SPL Life Sciences released a PCR Plate that can be used for Thermal cycler or real-time PCR equipment. Amplification is faster and more accurate through effective heat transfer with very thin walls. The clear well applies to PCR (thermal cycler). The white wells increase the fluorescence signal of qPCR by about 10 times that of transparent wells, so it is economical because it allows experiments with fewer reagents. The raised rims around each well allow tight sealing using a variety of procedures, including pressure-, adhesive-, and heat-sealing methods.

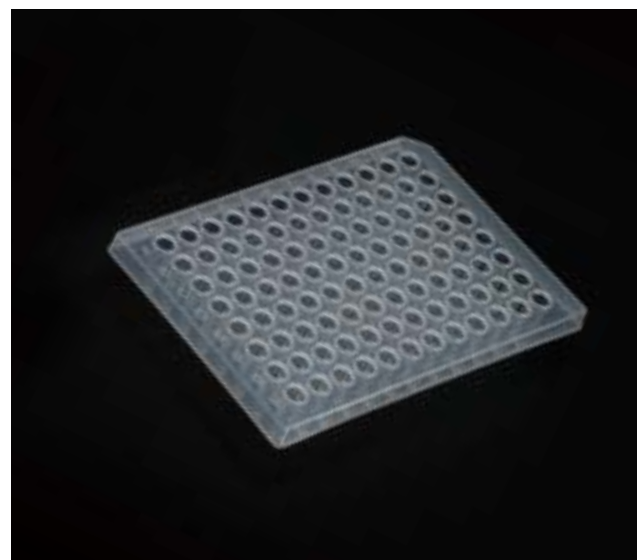
- Thin wall for fast PCR
- Medical-grade virgin polypropylene
- ANSI / SBS standard dimensions
- Raised well rims, optimized for heat-sealing tapes or adhesive sealing tape (SPLSEAL™ Pressure-sensitive Tape, Cat. No. 96004)
- Grouped by manufacturing mold cavity number to ensure the lowest variation
- DNase / RNase-free
- Human DNA-free



PCR Plate

Type	Cat. No.	Material	Well	Color	Profile	Skirt	Max. Volume (ml)	Cut corner	Packaging
	60096	PP	96	White	Low-profile	Full-skirt	0.20	A12, H12	10 / 50
	60396	PP	96	Clear	High-profile	Semi-skirt	0.30	A12	10 / 50

Molecular Analysis

Filter Tube

SPL Life Science provides a microcentrifuge tube filter based on the filter membrane for sample preparation of experiment. High-speed centrifugation through Filter Tube enables fast sample preparation and reduces contamination risk.

- 2 pore size: 0.22, 0.45 μm
- Standard Microcentrifuge Tube capacity: 1.5 ml (Cat. No. 60015)
- SPL 2.0 ml Microcentrifuge Tube compatible (Cat. No. 61020)
- Without Microcentrifuge Tube (Cat. No. 65115, 65215, 66115, 66215)



Filter Tube

Type	Cat. No.	Material	Membrane Material	Membrane Pore Size (μm)	Working Vol. (ml)	RCF Rating	Microcentrifuge Tube	Sterile	Packaging
U	65105	PP	Cellulose Acetate	0.22	0.50	15,000 x g	+	+	25 / 100
	65115	PP	Cellulose Acetate	0.22	0.50	15,000 x g	-	+	25 / 100
	65205	PP	Cellulose Acetate	0.45	0.50	15,000 x g	+	+	25 / 100
	65215	PP	Cellulose Acetate	0.45	0.50	15,000 x g	-	+	25 / 100
	66105	PP	Cellulose Acetate	0.22	0.50	15,000 x g	+	-	25 / 100
	66115	PP	Cellulose Acetate	0.22	0.50	15,000 x g	-	-	25 / 100
	66205	PP	Cellulose Acetate	0.45	0.50	15,000 x g	+	-	25 / 100
	66215	PP	Cellulose Acetate	0.45	0.50	15,000 x g	-	-	25 / 100

Vacuum Filter Tube

Hydrophilic PES membrane filter adopted to the product has less adsorption of protein or miscellaneous substances, and excellent durability. This provides a convenience for direct collection of samples by combining with 50 ml Conical Tube, which requires no secondary step to transfer them to after filtration. This is very useful for sterile-filtration of media or reagent at a small volume, and for separation of cells.

- Individual Packing
- 2 pore size: 0.22, 0.45 μm
- Non-pyrogenic
- Non-cytotoxic



Vacuum Filter Tube

Type	Cat. No.	Material (Funnel / Cap / Tube / Membrane)	Pore size (μm)	Volume (ml) (Funnel / Tube)	Sterile	Packaging
	50850	PS / HDPE / PP / PES	0.22	150.00 / 50.00	+	1 / 12
	50851	PS / HDPE / PP / PES	0.45	150.00 / 50.00	+	1 / 12

Molecular Analysis







Dialysis Chamber

Dialysis Chamber is used for various dialysis applications such as desalting, buffer exchange, labeling, reagent removal, drug binding experiment, cell growth and supply, virus purifications, blood transformation, etc. It is configured to rapidly and effectively dialysis a wide range of 3 ml ~ 15 ml volume, and guarantees 95 ~ 98% higher recovery rate than Dialysis tubing type.

- Excellent pH and chemical stability (pH 5 ~ 9)
- Membrane composition: Regenerated Cellulose (RC)
- Membrane Weight Cut-Off (MWCO): 3.5 K, 7 K, 14 K
- 3 ml Dialysis Chamber (Cat. No. 97003, 97007, 97014)
- 15 ml Dialysis Chamber (Cat. No. 97103, 97107, 97114)
- Float buoys for floating 3 ml dialysis Chamber (Cat. No. 97099)



Dialysis Chamber

Type	Cat. No.	Material (Body / Membrane)	Color	MWCO	Working Vol. (ml)	Packaging
	97003	PC / RC	Green	3.5 K	3.00 - 5.00	1 / 10
	97007	PC / RC	Blue	7 K	3.00 - 5.00	1 / 10
	97014	PC / RC	White	14 K	3.00 - 5.00	1 / 10
	97099	Sponge	White	-	-	10
	97103	PC / RC	Green	3.5 K	13.00 - 15.00	1 / 8
	97107	PC / RC	Blue	7 K	13.00 - 15.00	1 / 8
	97114	PC / RC	White	14 K	13.00 - 15.00	1 / 8

Gel Extractor

Gel Extractor is an easy-to-use and quick alternative to extract DNA and RNA bands from agarose gels after gel electrophoresis. Gel Extractor allows a precise excision of targeted gel material without sharps and blades. For one-handed, safe and easy gel cutting, the gel extractor is the cost effective solution.

- One-Handed gel easy cutting
- Disposable: no risk of cross contamination
- Cut DNA and RNA bands from agarose gels
- High yield recovery
- Non-pyrogenic
- Non-cytotoxic
- DNase / RNase-free
- Human DNA-free



Gel Extractor

Type	Cat. No.	Material	Cutter Dimensions w x l x h (mm)	Total Length (mm)	Packaging
	410511	PE	6.50 x 3.00 x 20.00	60.00	100



Blood Separation Tube

Blood Separation Tube is a product that facilitates the separation of peripheral blood mononuclear cell (PBMC) from the blood. The filter inside the tube prevents mixing of the PBMC, lymphocyte, and pellets

- Simplify injection of Separation media or blood samples
- Fast separation (15 min)
- Prevent the pellets from mixing after removal
- Non-pyrogenic
- Non-cytotoxic
- DNase / RNase-free
- Human DNA-free



Blood Separation Tube

Type	Cat. No.	Material	Bottom Type	External Dimension d x h (mm)	Total Vol. (ml)	Sample Vol. (ml)	Sterile	Packaging
	50915	PP	Conical	17.00 x 120.70	15.00	3.00 ~ 8.00	+	25 in rack / 500
	50916	PP	Conical	17.00 x 120.70	15.00	3.00 ~ 8.00	-	25 in rack / 500
	50950	PP	Conical	30.00 x 115.00	50.00	15.00 - 30.00	+	25 in rack / 300
	50951	PP	Conical	30.00 x 115.00	50.00	15.00 - 30.00	-	25 in rack / 300

Molecular Analysis





Cuvette

SPL spectrophotometer cuvettes use high-grade virgin resin and can be used for most spectrophotometer applications in the visible or UV range. Developed for single use to maintain accurate and consistent samples, it is compatible with most spectrophotometers and photometers. Replaces quartz cuvettes for DNA, RNA, protein purity and quantification, and other UV/VIS applications at 280 - 800 nm while avoiding scratching, washing and sample replacement contamination.

- Disposable 10 mm pathlength cuvettes designed for visible and UV/Vis assays.
- Standard 1.5 and 4.5 ml sample capacity.
- Clear two-sided cuvettes are ideal for fluorimetry and nephelometry, as well as spectrophotometry.
- Standard deviation is $< \pm 0.005$ extinction units between cuvettes.



Cuvette

Type	Cat. No.	Material	Type	External Dimension (mm)	Wavelength Range (nm)	Volume (ml)	Sterile	Packaging
	46015	PS	Standard	12.80 x 12.80 x 44.80	340 - 800	1.50	-	100
	46045	PS	Standard	12.60 x 12.60 x 44.80	340 - 800	4.50	-	100
	46115	PMMA	UV	12.80 x 12.80 x 44.80	280 - 800	1.50	-	100
	46145	PMMA	UV	12.60 x 12.60 x 44.80	280 - 800	4.50	-	100

UVMax™



SPL UVMax™ is a specialized plate intended for use in lower wavelength. The maximal transmittance is achieved between 260 and 280 nm, ideal for DNA and protein quantification. The plate with low background enables users to acquire more accurate experimental data. Unlike conventional laboratory cuvettes, SPL UVMax™ Plate allows for High-Throughput Screening (HTS) process and eliminates the need for expensive and fragile quartz / glass-type plates.

- 96well and 384well plate type
- Developed for determining concentrations of protein and / or nucleic acid
- Certified for low background and consistent performance at 260 and 280 nm
- Flat bottom
- Uniform surface homogeneity
- Lid not included
- Alphanumeric labelling

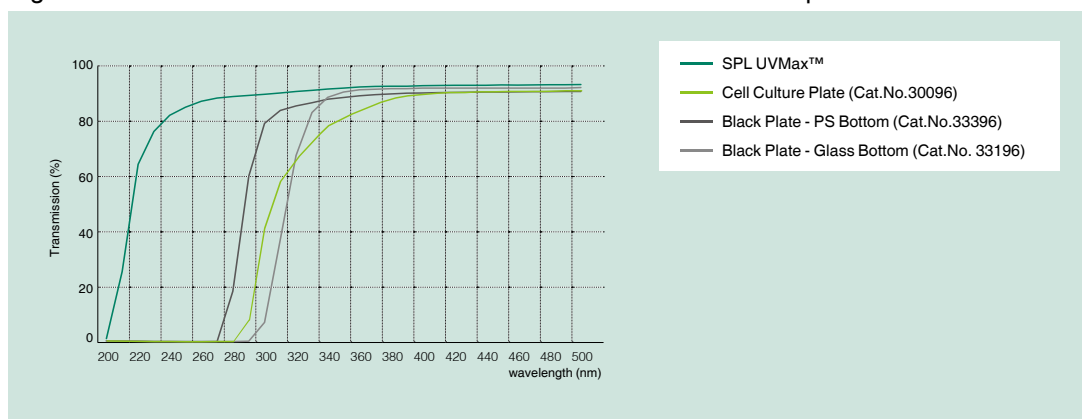
Fig. 1. % Transmittance of bottom materias: UVMax™ / SPL standard plates.



UVMax™

Type	Cat. No.	Material (Plate / Bottom)	Well Type	Bottom Type	External Dimensions w x l x h (mm)	Bottom Surface Area (cm ²)	Total Vol. (ml)	Packaging
	33096	PS / Film	96well	Flat	85.40 x 127.60 x 14.40	0.33	0.30	10 / 40
	330384	PS / Film	384well	Flat	85.40 x 127.60 x 14.40	0.07	0.20	1 / 20

Molecular Analysis

Bottle Top Filter

The hydrophilic PES membrane filter applied to the Bottle Top Filter is less adsorbing and durable. Bottle Top Filter is manufactured in accordance with the GL45 standard and can be used in various bottles. It can be used for sterilization of media or reagents, and for separation of cells, etc.

- Individual Packing
- 2 pore size: 0.22, 0.45 μm

- Non-pyrogenic
- Non-cytotoxic



Bottle Top Filter

Type	Cat. No.	Material (Funnel/Cap/Membrane)	Pore size (μm)	Funnel Vol. (ml)	Sterile	Packaging
	508150	PS / PP / PES	0.22	150.00	+	1 / 12
	508151	PS / PP / PES	0.45	150.00	+	1 / 12
	508500	PS / PP / PES	0.22	500.00	+	1 / 12
	508501	PS / PP / PES	0.45	500.00	+	1 / 12

Bottle Top Filter Unit

The hydrophilic PES membrane filter applied to the Bottle Top Filter is less adsorbing and durable. Bottle Top Filter Unit can be used conveniently that provided with a receiver bottle. It can be used for sterilization of media or reagents, and for separation of cells, etc.

- Individual Packing
- 2 pore size: 0.22, 0.45 μm
- Non-pyrogenic
- Non-cytotoxic



Bottle Top Filter Unit

Type	Cat. No.	Material (Funnel/Bottle/Cap/Membrane)	Pore size (μm)	Funnel Vol. (ml)	Bottle Vol. (ml)	Sterile	Packaging
	508502	PS / PS / PP / PES	0.22	500.00	500.00	+	1 / 12
	508503	PS / PS / PP / PES	0.45	500.00	500.00	+	1 / 12

Spin Column

Spin columns are supplied with column tubes and collection tubes. The columns provide fast and reliable extraction of high-quality DNA from a variety of samples including tissues, cells, plants, and blood.

- Large fragment size and high purity
- High quality and reproducible yields
- Suitable for many kinds of samples
- DNase / RNase-free
- Human DNA-free

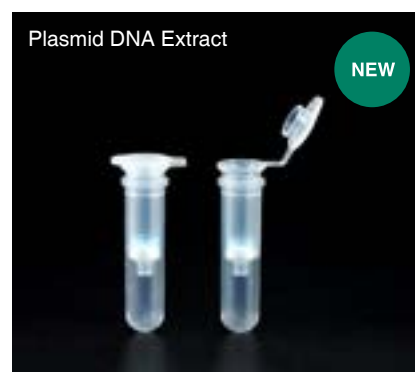

Spin Column

Type	Cat. No.	Materials	Application	Collection Tube Vol. (ml)	Spin Column Vol. (ml)	Sterile	Packaging
	66900	PP	DNA Extract	2.00	0.80	-	50 / 100
	66901	PP	RNA Extract	2.00	0.80	-	50 / 100
	66902	PP	Plasmid DNA Extract	2.00	0.80	-	50 / 100

Molecular Analysis

2-3. SPLPro-Crystal™

X-ray crystallography is a technique that uses X-ray diffraction patterns to determine high-resolution, three-dimensional structures of molecules such as proteins, small organic molecules, and materials. The substance of interest must be in crystalline form, which typically requires testing various crystallization conditions. The vapor diffusion method is a common technique used to crystallize proteins.

SPLPro-Crystal™ Plate are two different types of techniques within this category: hanging drop and sitting drop methods. Both of them consist of having a drop with protein solution situated either on top (hanging drop) or next to (sitting drop) a reservoir containing precipitant (e.g. a concentrated salt solution). As the water from the protein solution vaporizes, it transfers to the reservoir and crystallization occurs.

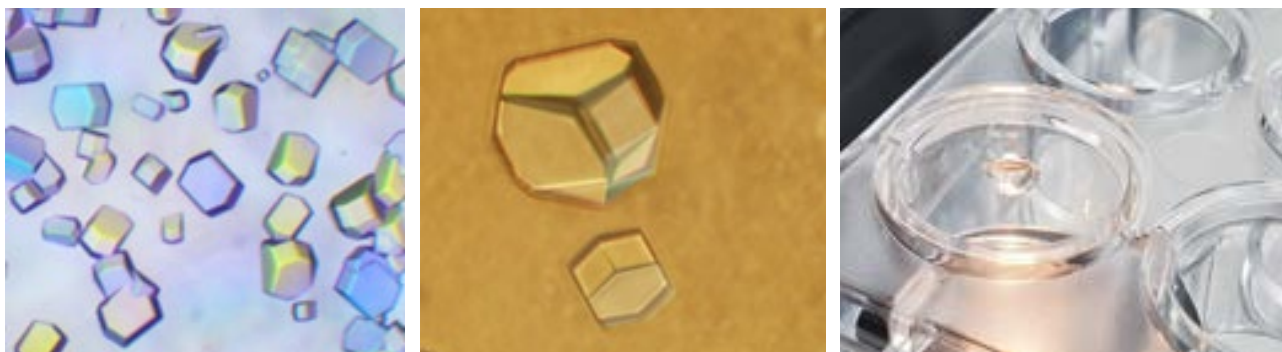

* Lysozyme crystals grown in the presence of 10 % v/v sodium chloride and 100 mM sodium acetate pH 4.6

Pro-Crystal™ Plate

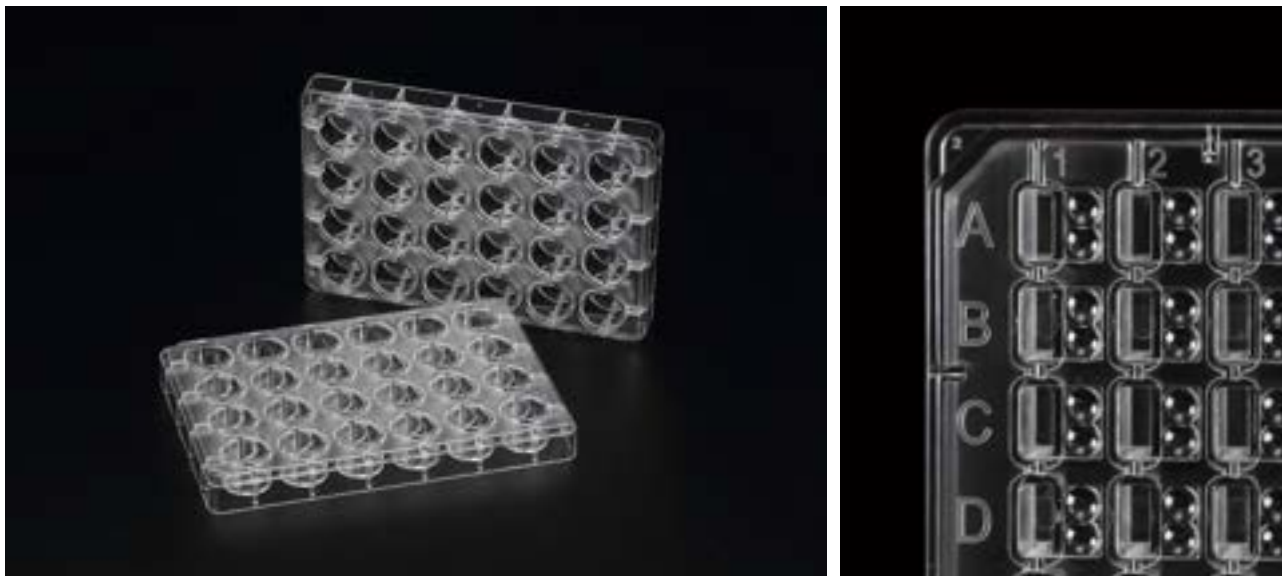

The SPLPro-Crystal™ Plate is a 24well hanging drop type that improves sealing and convenience to easily make many crystals. In addition, it is produced in SBS format to be used in automation equipment.

- 24well format (Cat.No. 334624, 334724)
- 96well format (Cat.No. 334696)
- Individually packaged
- Stackable
- Optically clear
- Lid provided with each well plate
- SBS standard format
- With sealant (Cat. No. 334724)

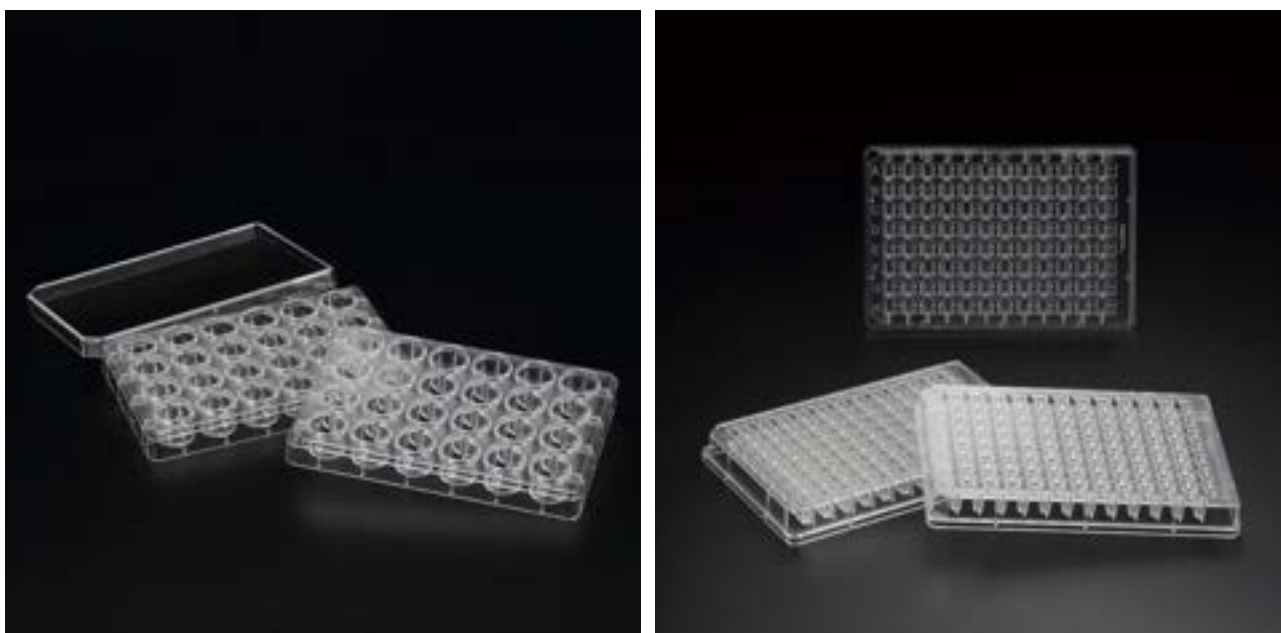

continued on next page

**SPLPro-Crystal™ Plate**

Type	Cat. No.	Type	Material	Dimensions w x l x h (mm)	Well Size (mm)	Reservoir well vol. (μl)	Drop well vol. (μl)	Sealant	Packaging
	334624	Hanging	PS	127.60 x 85.40 x 15.30	18.00	2,000.00	-	-	1 / 10
	334724	Hanging	PS	127.60 x 85.40 x 15.30	18.00	2,000.00	-	+	1 / 10
	334696	Sitting	PS	127.50 x 85.30 x 14.40	7.55 x 6.65	100.00	0.10 - 5.00	-	1 / 10

SPLPro-Crystal™ Coverslip

The material used for the SPLPro-Crystal™ Coverslip is a UV film developed by SPL Life Sciences and has the conditions suitable for protein crystals and high magnification microscopy.

- Diameter: 18.00 mm
- Flexible
- Thickness 0.19 mm
- Certified for low background and consistent performance at UV

**SPLPro-Crystal™ Coverslip**

Type	Cat. No.	Material	External Dimensions (mm)	Thickness (mm)	Packaging
○	20118	UVMax™ Film	18.00	0.19	50 / 200

Molecular Analysis

2-4. Accessories

SPL SEAL™

SPL SEAL™ provides a highly effective seal, preventing evaporation, and eliminating contamination and it is intended for use in general assays, genomics, compound, library, storage, bio-analytical assays, High-Throughput Screening (HTS) and drug discovery applications.

- Good optical property (low auto-fluorescence, high transparency)
 - Prevent evaporation and cross-contamination between wells
 - Working temperature range: 24 ~ 100 °C
 - Pre-cut, plate-sized sheets
 - Non-sterile
 - Thickness: 65 µm
-
- DNase / RNase-free



SPL SEAL™

Type	Cat. No.	Material	External Dimensions w x l (mm)	Color	Sterile	Packaging
	96000	PET / acrylate	143.00 x 79.00	Clear	-	100

SPL SEAL™ Pressure sensitive Tape

SPL SEAL™ Pressure-sensitive Tape is separated on both sides for convenient use. It is not sticky to the touch with a special adhesive, but it bonds strongly to the plate when pressure is applied, and can be used even with a raised rim. It does not fall even in environments with severe temperature changes such as PCR and minimizes sample evaporation. In addition, as it has excellent optical properties, it is suitable for related experiments such as ELISA, PCR, qPCR, and guarantees DNase/RNase-free quality level.

- Prevent evaporation and cross-contamination between wells
 - Pre-cut, plate-sized sheets
 - Non-sterile
 - DNase / RNase-free
 - Working temperature range: -80 ~ 100 °C
 - Thickness: 140 µm
 - Good optical property (low auto-fluorescence, high transparency)
 - Tight seals even with raised rims
 - Short- and long term storage
-
- DNase / RNase-free



SPL SEAL™ Pressure-sensitive Tape

Type	Cat. No.	Material	Dimensions	Color	Sterile	Packaging
	96004	PET / silicone	143.00 x 79.00	Clear	-	100

SPL SEAL™ Aluminum Tape

SPL SEAL™ Aluminum Tape is easy to attach and remove and can be stored samples for the short and long term. Aluminum tape can reduce cross-contamination of samples due to its high adhesion and can be used at -80 to 100°C. It is ideal for using light-sensitive samples and can be recovered of samples using a pipette without removing films. In addition, it is resistant to organic solvents such as DMSO.

- DMSO-resistant
- Non-sterile
- Working temperature range: -80 ~ 100 °C



SPL SEAL™ Aluminum Tape

Type	Cat. No.	Material	External Dimensions w x l (mm)	Color	Sterile	Packaging
	96005	Aluminum/silicone	143.00 x 79.00	Silver	-	100



SPL Lid

SPL Lid universally applicable to all SPL plates, including Cell Culture Plates and Immunoplates. The Lid, made of rigid polystyrene, prevents vaporization and contamination during assay processing, incubation or storage with SPL plates.

- Effective gas exchange lid inner design
- Prevent vaporization and contamination
- All plate type (Cat. No. 35001, 35101)
- 96well plate type (Cat. No. 35096, 35196)



SPL Lid

Type	Cat. No.	Material	External Dimensions w x l x h (mm)	Plate Type	Sterile	Packaging
	35001	PS	84.50 x 126.50 x 9.00	All	-	25 / 100
	35101	PS	84.50 x 126.50 x 9.00	All	+	25 / 100
	35096	PS	84.90 x 127.10 x 9.00	96	-	25 / 100
	35196	PS	84.90 x 127.10 x 9.00	96	+	25 / 100

Microbiology

SPL Life Sciences provides products that are feasible to all applications in microbiology, including dishes/plates for solid culture, and flasks for suspension culture. We offer a wide range of culture vessels, i.e., growth area and volume. Some of our products contain grids on the bottom to indicate the precise location of microbiological samples within the device. Also, accessories are available to assist culturing of microorganisms while preventing possible sources of contamination.

Our products are made of optically clear Polystyrene (PS) and Polycarbonate (PC) to allow precise observation of samples. PC especially has higher physical and chemical resistance. SPL Life Sciences products undergo strict sterilization process to completely remove potential presence of any unwanted microorganisms, and in turn increase the reliability of your experimental results.

3-1. Dishes & Vessels 100

Petri Dish	100
Partition Petri Dish	101
RODAC Plate.....	102
Square Dish.....	102
Tray Plate	103
Bacteria Culture Tube.....	103
Erlenmeyer Flask.....	104

3-2. Accessories 106

Loop & Needle	106
Spreader.....	106
Grid Sticker	107
Antibiotic Disc	107

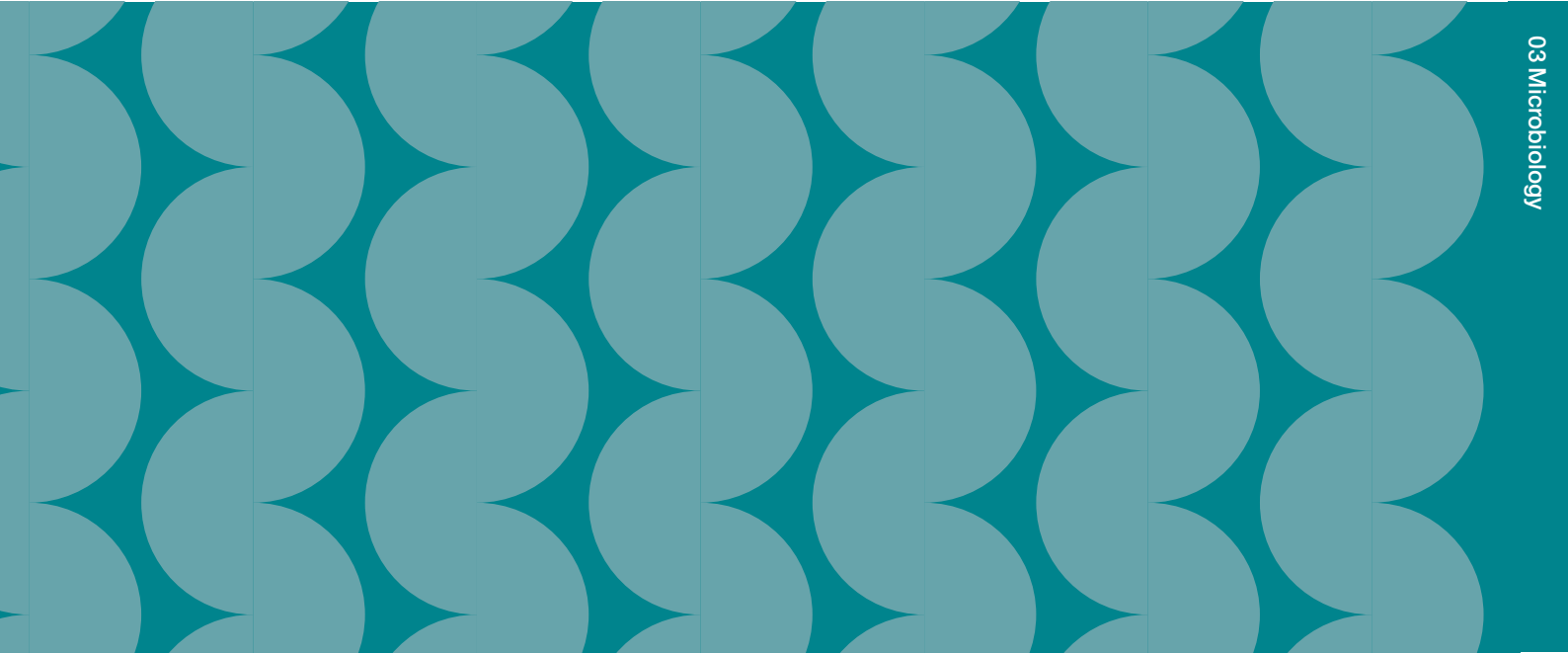

Microbiology

3-1. Dishes & Vessels

Petri Dish

SPL Life Sciences provides a large range (35 mm to 150 mm) of Petri Dishes for various laboratory purposes. All Petri Dishes are made with high quality polystyrene.

- Crystal grade Polystyrene
- Double packaging with 10090 (Cat. No. 10093)
- External grip for handling (Cat. No. 10035, 10050, 10060, 10101)
- Gridded bottom for counting (Cat. No. 10095, 10096)



Petri Dish



Type	Cat. No.	Dish Style d x h (mm)	Internal Dimensions d x h (mm)	Growth Area (cm ²)	External Grip	Sterile	Packaging
○	10035	35.00 x 10.00	35.00 x 9.60	9.40	+	+	20 / 500
○	10050	50.00 x 15.00 (Non-Air vent)	48.76 x 11.80	19.60	+	+	20 / 500
○	10060	60.00 x 15.00	52.80 x 12.80	21.50	+	+	20 / 500
○	10090	90.00 x 15.00	85.90 x 12.60	57.50	-	+	10 / 500
○	10091	90.00 x 20.00	86.20 x 17.70	58.00	-	+	10 / 200
○	10093	90.00 x 15.00	85.90 x 12.60	57.50	-	+	10 / 500
⊙	10095	90.00 x 15.00 (Grid)	85.72 x 12.64	57.50	-	+	10 / 200
⊕	10096	90.00 x 15.00 (Quadrant Grid)	85.72 x 12.64	57.50	-	+	10 / 500
○	10100	100.00 x 15.00	96.40 x 13.75	72.30	-	+	10 / 500
○	10101	90.00 x 20.00	87.48 x 16.40	60.80	+	+	10 / 200
○	10150	150.00 x 20.00	138.50 x 15.40	148.00	-	+	10 / 120
○	10151	150.00 x 25.00	138.57 x 23.30	148.00	-	+	5 / 120

Partition Petri Dish

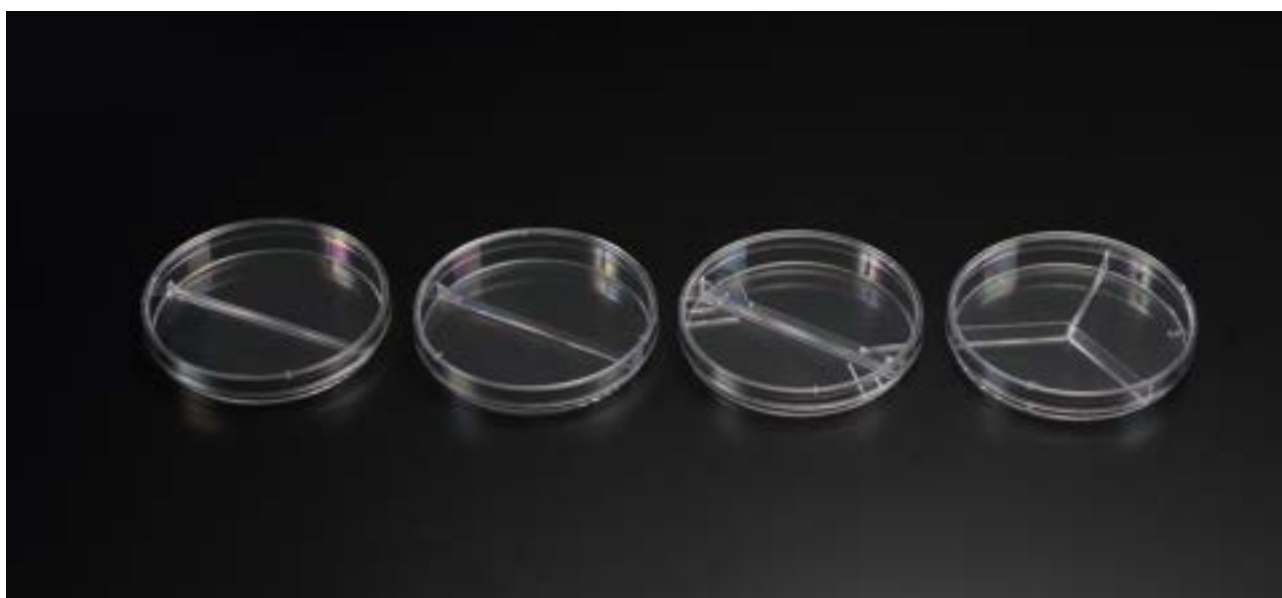
Partition Petri Dishes are designed for experiments that require multiple cells or medium types in a single dish. SPL Life Sciences provides 2-zoned Bi-Petri Dishes, 3-zoned Tri-Petri Dishes, and 4-zoned Quad-Petri Dishes to meet various needs. All products are sterilized and ready to use.



Partition Petri Dish

Type	Cat. No.	Dish Style d x h (mm)	Internal Dimensions d x h (mm)	Partition Height (mm)	Growth Area (cm ²)	External Grip	Sterile	Packaging
	10092	90.00 x 15.00	85.90 x 12.60	2.70	28.84	-	+	20 / 500
	10192	90.00 x 15.00	85.90 x 12.60	5.00	28.84	-	+	20 / 500
	10292	90.00 x 15.00	85.90 x 12.60	7.00	28.84	-	+	20 / 500
	10094	90.00 x 15.00	85.90 x 12.60	8.00	19.16	-	+	20 / 500
	10097	90.00 x 15.00	85.90 x 12.60	8.00	14.37	-	+	10 / 500

Microbiology



RODAC Plate

SPL Life Sciences provides RODAC (Replicate Organism Detection and Counting) Plates for monitoring surface contamination for various purposes. Plates are made with high-quality polystyrene.

- Gridded and convex bottom ensures direct contact occurs between medium surface and the test surface while sampling (Cat. No. 10061)
- Gridded and flat bottom (Cat. No. 10063)



RODAC Plate

Type	Cat. No.	Bottom Type	Dish Style d x h (mm)	Internal Dimensions d x h (mm)	Growth Area (cm ²)	External Grip	Sterile	Packaging
	10061	Convex	60.00 x 16.70	57.40 x 9.50	21.50	-	+	20 / 500
	10063	Flat	59.50 x 15.80	54.90 x 8.50	21.50	-	+	20 / 500



Square Dish

Square Dishes have been widely used for microbiology applications, such as colony tracing and picking. Our Square Dishes with large surface areas and gridded bottoms are useful for tracing the location of individual colony.

- Ideal for colony formation and enhancing plating efficiency
- Useful for colony counting or picking



Square Dish

Type	Cat. No.	Material	External Dimensions w x l x h (mm)	Internal Dimensions w x l x h (mm)	Growth Area (cm ²)	Sterile	Packaging
	11125	PS	126.40 x 126.40 x 20.00	118.70 x 118.70 x 11.60	139.00	+	10 / 240
	10245	PS	243.00 x 243.00 x 19.30	227.50 x 227.50 x 13.20	500.00	+	5 / 20
	11245	PS	243.00 x 243.00 x 27.30	227.50 x 227.50 x 21.20	500.00	+	5 / 20

Tray Plate

The rectangular tray dishes provide larger surface area to ensure easy handling compared to round dishes for microbiological applications. The external dimensions of Tray Plates are identical to those of standard cell culture plates for broader application.



Tray Plate

Type	Cat. No.	Material	External Dimensions w x l x h (mm)	Well Dimensions w x l x h (mm)	Growth Area (cm ²)	Sterile	Packaging
	31001	PS	127.94 x 85.50 x 16.25	109.64 x 73.46 x 11.60	80.54	+	10 / 100



Bacteria Culture Tube

Bacteria Culture Tubes are designed to incubate pathogenic microbial cells. During cultivation of pathogenic microorganisms, researchers can handle the tube while protecting the sample from infectious contamination. Bacteria Culture tubes are sterilized after complete packaging to eliminate contamination. The air through the culture tube can be filtered by 0.22 µm syringe filter on the center of the tube cap.

- Sampling of the culture supernatant can be performed without infection during the incubation of pathogenic microbial cells such as *mycobacterium tuberculosis*, etc.
- Syringe filter is mounted on the cap to minimize contamination from pathogenic microorganisms.
- 15 / 50 ml conical tube size
- Suitable for shaking incubation



Bacteria Culture Tube

Type	Cat. No.	Material (Tube / Cap / Filter)	Cap Type	External Dimensions d x h (mm)	Total Vol. (ml)	Sterile	Packaging
	59015	PP / HDPE / PVDF	Filter	17.00 x 140.50	15.00	+	5 / 50
	59050	PP / HDPE / MCE	Filter	30.00 x 137.90	50.00	+	5 / 50

Microbiology

Erlenmeyer Flask

Erlenmeyer Flasks are most widely used in microbiology for the preparation of microbial suspension culture. The shape of the flask allows stable swirling for effective mixing of solutions. SPL Life Sciences provides Erlenmeyer flask in five different volumes.

- Suitable for suspension cultures (animal cells, bacteria, fungi, plant callus, etc.)
- Require shaking apparatus (optimization of cell seeding density and working volume is recommended, depending on the type of cell)
- Plug & Filter caps are available for all flask types
- Non-treated
- Durable & transparent polycarbonate
- Autoclavable
- Non-pyrogenic
- Non-cytotoxic
- DNase / RNase-free
- Human DNA-free



continued on next page

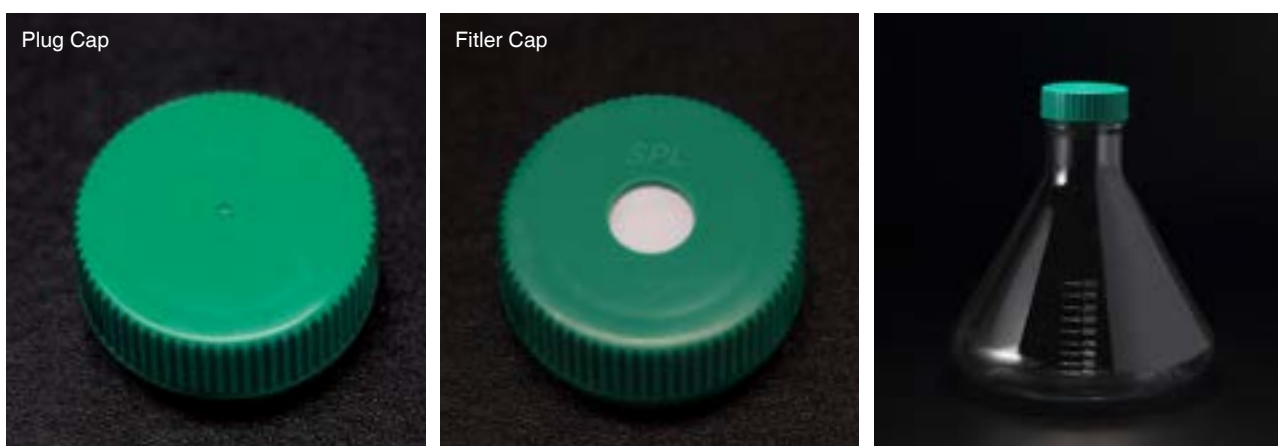

Erlenmeyer Flask

Type	Cat. No.	Material (Body / Cap)	Cap Type	Bottom Type	Total Vol. (ml)	Sterile	Packaging
	73250	PC/PP	Plug	Plain	250.00	+	1 / 8
	74250	PC/PP	Filter	Plain	250.00	+	1 / 8
	75250	PC/PP	Plug	Plain	250.00	-	1 / 8
	76250	PC/PP	Filter	Plain	250.00	-	1 / 8
	73500	PC/PP	Plug	Plain	500.00	+	1 / 8
	74500	PC/PP	Filter	Plain	500.00	+	1 / 8
	75500	PC/PP	Plug	Plain	500.00	-	1 / 8
	76500	PC/PP	Filter	Plain	500.00	-	1 / 8
	73000	PC/PP	Plug	Plain	1,000.00	+	1 / 4
	74000	PC/PP	Filter	Plain	1,000.00	+	1 / 4
	75000	PC/PP	Plug	Plain	1,000.00	-	1 / 4
	76000	PC/PP	Filter	Plain	1,000.00	-	1 / 4
	73002	PC/PP	Plug	Plain	2,000.00	+	1 / 6
	74002	PC/PP	Filter	Plain	2,000.00	+	1 / 6
	75002	PC/PP	Plug	Plain	2,000.00	-	1 / 6
	76002	PC/PP	Filter	Plain	2,000.00	-	1 / 6
	73003	PC/PP	Plug	Plain	3,000.00	+	1 / 4
	74003	PC/PP	Filter	Plain	3,000.00	+	1 / 4
	75003	PC/PP	Plug	Plain	3,000.00	-	1 / 4
	76003	PC/PP	Filter	Plain	3,000.00	-	1 / 4

Microbiology

3-2. Accessories



Loop & Needle

Disposable Loop and Needle consists of a loop on one side and a needle on the other, used for the inoculation of microorganisms. Two different sizes are available.

- Suitable for microbe inoculation
- Dual purpose: a loop on one end and a needle on the other
- Color coded for sizes (White for 1 µl, Blue for 10 µl)
- DNase / RNase-free
- Human DNA-free



Loop & Needle

Type	Cat. No.	Material	Size (µl)	Length (mm)	Sterile	Packaging
	90001	PP	1.00	195.00	+	10 / 500
	90010	PP	10.00	195.00	+	10 / 500

Spreader

Disposable Spreader is used for spreading microorganisms, which is sterilized before the release.

- Suitable for spreading of microbe samples
- Autoclavable



Spreader

Type	Cat. No.	Material	Dimensions w x l (mm)	Sterile	Packaging
	90050	PP	37.00 x 143.00	+	10 / 500

Grid Sticker

SPL Life Sciences has released Grid Stickers as an exclusive accessory for use with petri dish. The sticker is made of transparent label and can be attached swiftly and neatly to the bottom of petri dish. It is designed as 1 mm- and 10 mm- interval grid pattern, and can be applied to various experiments, including colony counting, plant growth measurement, and clear zone measurement for fungal test.

- For 90 - 100 mm Petri dish
- Thickness: 70 μm
- Labels remain firmly attached at temp. from 4 to 40°C

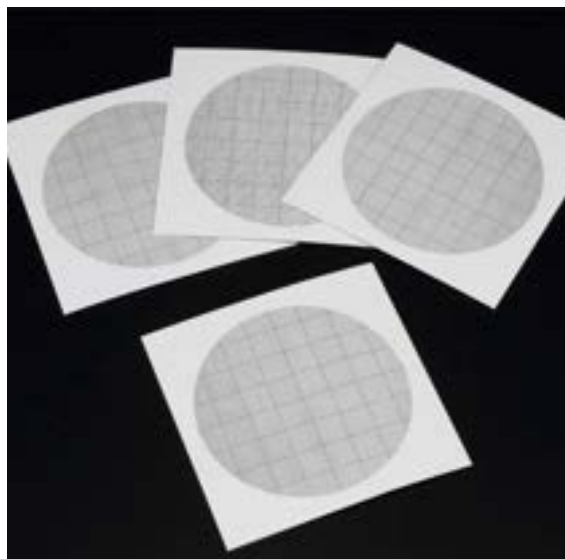

Grid Sticker

Type	Cat. No.	Material	Dimension (mm)	Major Grid (mm)	Minor Grid (mm)	Packaging
	90100	Tetron	76.25	10.00	1.00	100 / 200

Antibiotic Disc

Antibiotic Disc is used to determine the susceptibility of bacteria to different antibiotics by paper disc assay. Antibiotic Discs made of cellulose paper have excellent liquid absorption.

- Non-cytotoxic



Antibiotic Disc

Type	Cat No.	Material	Dimension (mm)	Thickness (mm)	Packaging
	99000	Cellulose	6.00	0.70 ~ 0.80	1,000

Handling & Storage

Most biological samples and reagents should be stored and maintained in the proper condition. SPL provides handling and storage tools that are durable in all possible conditions.

4-1. Liquid Handling 110

Serological Pipette.....	110
Aspiration Pipette.....	112
Micropipette Tip	112
Q-suction 8-Tip	114
Dropper.....	114
Blender Bag	115

4-2. Tubes 116

Conical Tube.....	116
Snap Tube	118
25 ml Conical Tube	119
5 ml Screw Tube	120
5 ml Snap Tube.....	121
Septum Tube	122
Test Tube.....	123
Micro Vial	124
Reinforced Tube	125
250 ml conical tube	126
1.5 ml Strip Tube.....	127
Protein Safe	127
Microcentrifuge Tube	128

4-3. Racks & Boxes 130

Conical Tube Rack I.....	130
Conical Tube Rack II.....	130
Snap Tube Rack	131
2well Conical Tube Rack.....	131
5 ml Tube Rack.....	132
Stacker Microtube Rack.....	132
Microtube Rack.....	133
Standing Microtube Rack.....	133
PCR Tube Rack	133
Storage Box	134
Conical Tube Storage Box	134
25 ml Tube Storage Box.....	135
5 ml Tube Storage Box.....	135

4-4. Bottles 136

Wide-Mouth Bottle (HDPE).....	137
Wide-Mouth Bottle (Amber)	138
Wide-Mouth Bottle (PP)	139
Media Bottle.....	140
Narrow-Mouth Bottle (HDPE).....	141
Narrow-Mouth Bottle (Amber).....	142
Narrow-Mouth Bottle (PP).....	143
Biotainer	144
Storage Bottle	144
Port Cap.....	145

4-5. Storage & Accessories ... 146

Deep Well Plate	146
Sealing Mat.....	147
Deep Well Reservoir.....	148
Reservoirs	148
Storage Plate 96well.....	149
Omni Box.....	150
Autoclaving Jar	150
MOUZIP®.....	150
25 ml Tube Adapter.....	151
5 ml Snap Tube Adapter	151
Label Protection Tape.....	152
Glove (Safe Guard).....	153
Disposable Tweezers	154
Water Sample Bottle.....	154
Biohazard Bag	155
Silicone Tubing	156

Handling & Storage

4-1. Liquid Handling

A small difference in liquid quantity may result in experimental values that are significantly different, and thus precise handling of liquids is crucial to obtaining reliable and reproducible results. SPL Life Sciences is confident in providing high precision, world-leading quality serological pipettes and tips in various configurations.

Serological Pipette

SPL Serological Pipettes are classified by sample volume. Ascending & descending graduations facilitate the reading of both dispensing and remaining volume.

- Six different volumes
- Color-coded for easy identification
- Various packaging methods
- Cuttingtop Pipette for viscous liquid handling (Cat. No. 91110)
- Non-pyrogenic
- Non-cytotoxic
- DNase / RNase-free
- Human DNA-free



continued on next page



Serological Pipette

Type	Cat. No.	Material	Color Code	Working Vol. (ml)	Sterile	Packaging
Individual Packaging(Paper/Plastic) - Inbox						
	91001	PS	Yellow	1.00	+	1 / 200 / 800
	91002	PS	Green	2.00	+	1 / 150 / 600
	91005	PS	Blue	5.00	+	1 / 100 / 400
	91010	PS	Orange	10.00	+	1 / 100 / 400
	91025	PS	Red	25.00	+	1 / 50 / 200
	91050	PS	Purple	50.00	+	1 / 40 / 160
Bulk Packaging(Paper/Plastic)						
	93001	PS	Yellow	1.00	+	50 / 1,000
	93002	PS	Green	2.00	+	50 / 1,000
	93005	PS	Blue	5.00	+	50 / 500
	93010	PS	Orange	10.00	+	50 / 500
	93025	PS	Red	25.00	+	25 / 200
	93050	PS	Purple	50.00	+	25 / 200
Individual Packaging(Paper/Plastic) - Bulk						
	95001	PS	Yellow	1.00	+	1 / 200 / 800
	95002	PS	Green	2.00	+	1 / 150 / 600
	95005	PS	Blue	5.00	+	1 / 100 / 400
	95010	PS	Orange	10.00	+	1 / 100 / 400
	95025	PS	Red	25.00	+	1 / 50 / 200
	95050	PS	Purple	50.00	+	1 / 40 / 160
Bulk Packaging(Plastic/Plastic)						
	95205	PS	Blue	5.00	+	1 / 100 / 400
	95210	PS	Orange	10.00	+	1 / 100 / 400
	95225	PS	Red	25.00	+	1 / 50 / 200
	95250	PS	Purple	50.00	+	1 / 40 / 160
Cuttingtop Pipette						
	91110	PS	Orange	10.00	+	1 / 100 / 400

Handling & Storage





Aspiration Pipette

SPL Aspiration Pipettes are useful for rapidly collecting and releasing liquid samples.

- No graduations
- Non-pyrogenic
- DNase / RNase-free
- No plugs
- Non-cytotoxic
- Human DNA-free



Aspiration Pipette

Type	Cat. No.	Material	Working Vol. (ml)	Sterile	Packaging
	94001	PS	1.00	+	1 / 200 / 800
	94002	PS	2.00	+	1 / 150 / 600
	94005	PS	5.00	+	1 / 100 / 400
	94010	PS	10.00	+	1 / 100 / 400

Micropipette Tip

SPL Micropipette Tips are classified by sample volume and types. They are designed to fit in wide range of single and multi-channel pipettes.

- Diverse product range
- Excellent compatibility
- Easily distinguished by color
- Reduces chances of making errors
- Extra-long design
(Cat. No. 92020, 92023, 92021, 92022, 92024)
- Autoclavable





- Non-pyrogenic
- Non-cytotoxic
- DNase / RNase-free
- Human DNA-free



continued on next page



Micropipette Tip

Type	Cat. No.	Type	Color	Vol. (µl)	Sterile	Packaging
	92010	Bulk Tip	Clear	0.50 – 10.00	-	1,000 / bag, 40 bags / box
	92200	Bulk Tip	Yellow	20.00 – 200.00	-	1,000 / bag, 20 bags / box
	92000	Bulk Tip	Blue	100.00 – 1,000.00	-	1,000 / bag, 10 bags / box
	92020	Bulk Tip	Clear	100.00 – 1,000.00	-	500 / bag, 20 bags / box
	92013	Tip in Rack	Clear	0.50 – 10.00	+	96 tips / rack, 100 racks / box
	92203	Tip in Rack	Yellow	20.00 – 200.00	+	96 tips / rack, 100 racks / box
	92003	Tip in Rack	Blue	100.00 – 1,000.00	+	96 tips / rack, 60 racks / box
	92023	Tip in Rack	Clear	100.00 – 1,000.00	+	96 tips / rack, 60 racks / box
	92011	Filter Tip in Rack	Clear	0.50 – 10.00	+	96 filter tips / rack, 100 racks / box
	92201	Filter Tip in Rack	Clear	20.00 – 200.00	+	96 filter tips / rack, 100 racks / box
	92001	Filter Tip in Rack	Clear	100.00 – 1,000.00	+	96 filter tips / rack, 60 racks / box
	92021	Filter Tip in Rack	Clear	100.00 – 1,000.00	+	96 filter tips / rack, 60 racks / box
	92012	Refill Tip	Clear	0.50 – 10.00	+	960 tips / pack, 10 packs / box
	92202	Refill Tip	Yellow	20.00 – 200.00	+	960 tips / pack, 10 packs / box
	92002	Refill Tip	Blue	100.00 – 1,000.00	+	480 tips / pack, 10 packs / box
	92022	Refill Tip	Clear	100.00 – 1,000.00	+	576 tips / pack, 10 packs / box
	92014	Rack		0.50 – 10.00	-	100 racks / box
	92204	Rack		20.00 – 200.00	-	100 racks / box
	92004	Rack		100.00 – 1,000.00	-	60 racks / box
	92024	Rack		100.00 – 1,000.00	-	60 racks / box

Handling & Storage

Q-Suction 8-Tip

Vacuum suction pumps are generally used to aspirate liquids such as media from cell cultures or supernatant. The Q-Suction 8-Tip fits on the vacuum pump tubing so that it can be used to remove media and solutions from 8 wells simultaneously on the 96 or 384 well plates for ELISA, HLA, Tissue Typing, and other applications.

- Disposable
- Sterile (Cat. No. 92108, 92208)
- Individually packaged (Cat. No. 92108, 92208)

- Non-pyrogenic
- Non-cytotoxic
- DNase / RNase-free
- Human DNA-free



Q-Suction 8-Tip

Type	Cat. No.	Material	Dimensions w x l x h (mm)	Sterile	Packaging
	92108	PP	72.90 x 13.70 x 56.10	+	1 / 25
	92208	PP	72.90 x 13.70 x 56.10	+	1 / 50
	92308	PP	72.90 x 13.70 x 56.10	-	50



Dropper

SPL Droppers are designed for handling of liquid samples and reagents for general research.

- Suitable for rapidly dividing and transporting liquid samples



Dropper

Type	Cat. No.	Material	Total Length (mm)	Working Vol. (ml)	Total Vol. (ml)	Sterile	Packaging
	410501	PE	136.30	0.30	0.5	-	200 / 12,000
	410502	PE	138.17	1.00	1	-	500 / 9,000

Blender Bag



SPL Blender Bag is laboratory plasticware designed for use in industrial microbiology labs such as food & beverage, environmental / water testing, etc. A complete range of bags, sterile certified, can be used to the safe and quick preparation of solid samples before biological and chemical analysis.

They fit to all conventional 400 ml lab blenders and are adapted to all samples.

- Flexible and transparent bag compatible with any lab blender
- Non-woven filter for stronger filtration power (< 250 µm)
- Wire tie for convenient experiments (Cat.No. 97002)
- Disposable
- Non-pyrogenic
- Non-cytotoxic
- DNase / RNase-free
- Human DNA-free



Blender Bag

Type	Cat. No.	Material	Type	Dimensions (mm)	Working Vol. (ml)	Sterile	Packaging
	97000	PE	Standard	300.00 x 190.00	80.00 – 400.00	+	50 / 500
	97001	PE	Lateral	300.00 x 190.00	80.00 – 400.00	+	50 / 500
	97002	PE	Lateral, Wire	300.00 x 190.00	80.00 – 400.00	+	50 / 500

Handling & Storage

4-2. Tubes

Most biological samples and reagents should be stored and maintained in appropriate conditions depending on the purpose of your experiments. Our products are not solely designed to store your liquid samples, but to provide extra features useful in experiments, such as centrifugation-feasibility and light shielding function. Therefore, choosing appropriate tubes or bottles will allow you to store your liquid samples and conduct experiments accordingly.

Conical Tube

Conical Tubes are widely used in laboratories for various purposes, including but not limited to storing samples and conducting high-speed centrifugation. SPL Life Sciences provides high-strength, non-toxic conical tubes to meet the demands of customers.

Amber Conical Tubes are suitable for handling and storing light-sensitive samples. Materials used for Amber Conical Tubes significantly decrease light transmission over the visible wavelength spectrum compared to those of clear polypropylene tubes

- Tight sealing screw cap
- External graduations with marking area
- Packed in zipper bags
- Polystyrene (transparent), conical tubes (Cat. No. 51015, 51115, 51150)
- Skirted, self-standing type (Cat. No. 50250)
- For high speed centrifugation (Cat. No. 50040)
- Provided in rack (Cat. No. 50115, 50150, 51150)
- Amber type (Cat. No. 54015, 54115, 54050, 54150)
- Non-pyrogenic
- Non-cytotoxic
- DNase / RNase-free
- Human DNA-free







continued on next page



**Conical Tube**

Type	Cat. No.	Bottom Type	Material (Tube / Cap)	External Dimensions d x h (mm)	Total Vol. (ml)	RCF Rating	Sterile	Packaging
------	----------	-------------	-----------------------	--------------------------------	-----------------	------------	---------	-----------



Conical Tube - In sleeves

	50015	Conical	PP / HDPE	17.00 x 120.70	15.00	13,000 x g	+	50 in sleeve / 500
	51015	Conical	PS / HDPE	17.00 x 120.70	15.00	3,000 x g	+	50 in sleeve / 500
	50050	Conical	PP / HDPE	30.00 x 116.70	50.00	14,000 x g	+	25 in sleeve / 500
	50515	Skirted	PP / HDPE	17.00 x 120.00	15.00	-	+	50 in sleeve / 500
	50250	Skirted	PP / HDPE	30.00 x 116.00	50.00	-	+	25 in sleeve / 500
	50040	Conical	PP / HDPE	30.00 x 115.00	40.00	35,000 x g	+	10 in sleeve / 100

Conical Tube - In racks

	50115	Conical	PP / HDPE	17.00 x 120.70	15.00	13,000 x g	+	25 in rack / 500
	51115	Conical	PS / HDPE	17.00 x 120.70	15.00	3,000 x g	+	25 in rack / 500
	50150	Conical	PP / HDPE	30.00 x 115.00	50.00	14,000 x g	+	25 in rack / 300
	51150	Conical	PS / HDPE	30.00 x 115.00	50.00	3,000 x g	+	25 in rack / 300

Amber Conical Tube

	54015	Conical	PP / HDPE	17.00 x 120.70	15.00	13,000 x g	+	50 in sleeve / 500
	54115	Conical	PP / HDPE	17.00 x 120.70	15.00	13,000 x g	+	50 in sleeve / 200
	54050	Conical	PP / HDPE	30.00 x 115.00	50.00	14,000 x g	+	25 in sleeve / 500
	54150	Conical	PP / HDPE	30.00 x 115.00	50.00	14,000 x g	+	25 in sleeve / 200

Handling & Storage

Snap Tube

Snap Tubes are widely used in laboratories for various reasons, from simply storing samples to conducting high-speed centrifugation. Snap Tubes are especially helpful because one can open and close the tube with just one hand.

- Snap cap with tight sealing
- 80% of the nominal volume
- External graduations with marking area
- Skirted, self-standing type (Cat. No. 50415, 50560)
- Provided in snap tube racks (Cat. No. 50315, 50550)
- Non-pyrogenic
- Non-cytotoxic
- DNase / RNase-free
- Human DNA-free



Snap Tube

Type	Cat. No.	Bottom Type	Material	External Dimensions d x h (mm)	Total Vol. (ml)	RCF Rating	Sterile	Packaging
Snap Tube - In sleeves								
	50215	Conical	PP	16.00 x 120.00	15.00	5,500 x g	+	50 in sleeve / 500
	50415	Skirted	PP	16.00 x 120.00	15.00	-	+	50 in sleeve / 500
	50450	Conical	PP	28.00 x 116.00	50.00	9,000 x g	+	25 in sleeve / 500
	50650	Skirted	PP	28.00 x 117.00	50.00	-	+	25 in sleeve / 500
Snap Tube - In racks								
	50315	Conical	PP	16.00 x 120.00	15.00	5,500 x g	+	25 in rack / 500
	50550	Conical	PP	28.00 x 116.00	50.00	9,000 x g	+	25 in rack / 300



25 ml Conical Tube

25 ml Conical Tube is optimized for storage of samples with a volume of 25 ml or less. The shorter tube compared to the 50 ml tube is easy to use and minimizes sample contamination. It can be used with a 50 ml centrifuge rotor using the dedicated adapter.

- Tight sealing screw cap
- Imprinted external graduations with marking area
- Packed in zipper bags
- 25 ml Tube Adapter for 50 ml rotor (Cat. No. 52025)
- Compatible with Conical Tube Rack II (Cat. No. 52150)
- Non-pyrogenic
- Non-cytotoxic
- DNase / RNase-free
- Human DNA-free



25 ml Conical Tube

Type	Cat. No.	Bottom Type	Material (Tube / Cap)	External Dimensions d x h (mm)	Total Vol. (ml)	RCF Rating	Sterile	Packaging
	50025	Conical	PP / HDPE	30.00 x 77.20	25.00	18,000 x g	+	25 / 200
	50225	Skirted	PP / HDPE	30.00 x 77.20	25.00	-	+	25 / 200

25 ml Tube Adapter

Type	Cat. No.	Material	External Dimensions d x h (mm)	RCF rating	Packaging
	52025	Acetal	28.50 x 52.00	18,000 x g	6

Handling & Storage



5 ml Screw Tube

5 ml Screw Tube is ideal for experiments requiring larger sample volumes, between 1.5 ml and 5 ml. Screw type cap is sophisticatedly designed to prevent possible contamination, and to allow safe handling. 5 ml Screw Tube is applicable to centrifuge independently, and can also be inserted into its adapter for 15 ml rotor.

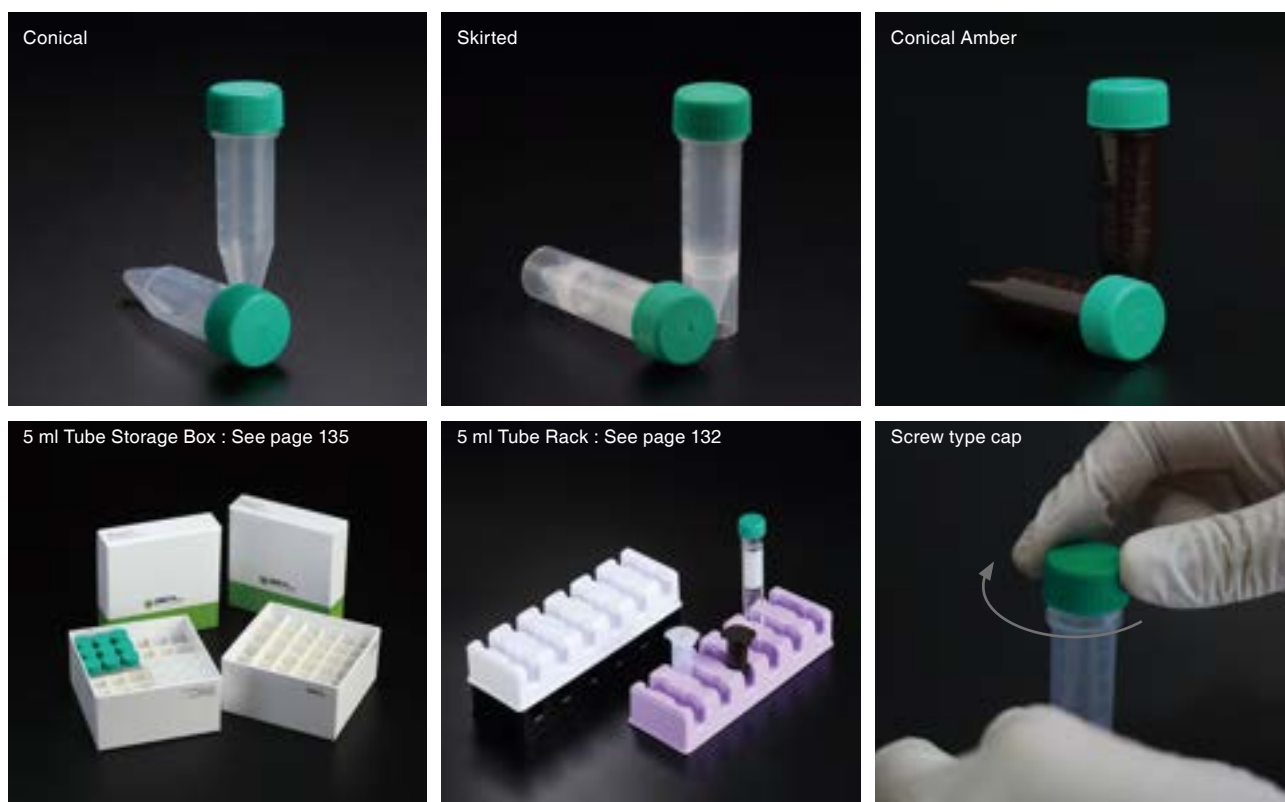
- Screw cap with tight sealing
- Imprinted external graduations with marking area
- Sterile (Cat. No. 51105, 53105, 56105)
- Non-pyrogenic
- Non-cytotoxic
- DNase / RNase-free
- Human DNA-free



5 ml Screw Tube

Type	Cat. No.	Type	Material (Tube / Cap)	External Dimensions d x h (mm)	Total Vol. (ml)	RCF Rating	Sterile	Packaging
Clear Type								
	51005	Conical	PP / HDPE	16.00 x 66.00	5.00	25,000 x g	-	100 in sleeve / 200
	51105	Conical	PP / HDPE	16.00 x 66.00	5.00	25,000 x g	+	100 in sleeve / 200
	53005	Skirted	PP / HDPE	16.00 x 69.10	5.00	-	-	100 in sleeve / 200
	53105	Skirted	PP / HDPE	16.00 x 69.10	5.00	-	+	100 in sleeve / 200
Amber Type								
	56005	Conical	PP / HDPE	16.00 x 66.00	5.00	25,000 x g	-	100 in sleeve / 200
	56105	Conical	PP / HDPE	16.00 x 66.00	5.00	25,000 x g	+	100 in sleeve / 200

5 ml Snap Tube Adapter

Type	Cat. No.	Material	External Dimensions d x h (mm)	RCF rating	Packaging
	52005	Acetal	16.60 x 78.24	25,000 x g	10

5 ml Snap Tube



5 ml Snap Tubes are widely used in laboratories for multiple purposes, from storage of samples to high speed centrifugation. Snap Tubes can assist users during experiments by enabling easy one-hand opening and closing of the tubes by providing snap type cap.

Amber 5 ml Snap Tubes are suitable for handling and storing light-sensitive samples. Materials used for Amber 5 ml Snap Tubes significantly decrease light transmission over the visible wavelength spectrum compared to those of clear polypropylene tubes

- Snap cap with tight sealing
- External graduations with marking area
- Sterile (Cat. No. 50105, 55105, 54105)
- Skirted (Cat. No. 55005, 55105)
- Amber type (Cat. No. 54005, 54105)
- 5 ml Snap Tube Adapter for 15 ml rotor (Cat. No. 52005)
- Non-pyrogenic
- Non-cytotoxic
- DNase / RNase-free
- Human DNA-free



5 ml Snap Tube

Type	Cat. No.	Bottom Type	Material	External Dimensions d x h (mm)	Total Vol. (ml)	RCF Rating	Sterile	Packaging
Clear Type								
	50005	Conical	PP	20.00 x 62.00	5.00	25,000 x g	-	100 in sleeve / 200
	50105	Conical	PP	20.00 x 62.00	5.00	25,000 x g	+	100 in sleeve / 200
	55005	Skirted	PP	20.00 x 63.30	5.00	-	-	100 in sleeve / 200
	55105	Skirted	PP	20.00 x 63.30	5.00	-	+	100 in sleeve / 200
Amber Type								
	54005	Conical	PP	20.00 x 62.00	5.00	25,000 x g	-	100 in sleeve / 200
	54105	Conical	PP	20.00 x 62.00	5.00	25,000 x g	+	100 in sleeve / 200

5 ml Snap Tube Adapter

Type	Cat. No.	Material	External Dimensions d x h (mm)	RCF rating	Packaging
	52005	Acetal	16.60 x 78.24	25,000 x g	10

Handling & Storage



Septum Tube

SPL Life Sciences provides a new type of Conical Tube including highly resilient silicone septum in the center of the cap. Septum Tube is effective in completely blocking external contaminants because it is not necessary to open the cap to handle the sample. Silicone septum with PTFE coating is highly resistant to various solvents and fully recovers even repeated use of syringes.

- Tight sealing screw cap
- Silicone septum with PTFE coating
- External graduations with marking area
- Provided in rack
- Packed in zipper bags
- Non-pyrogenic
- Non-cytotoxic
- DNase / RNase-free
- Human DNA-free



Septum Tube

Type	Cat. No.	Material (Tube / Cap)	Septum Material	External Dimensions d x h (mm)	Total Vol. (ml)	RCF Rating	Sterile	Packaging
	50715	PP / HDPE	Silicone / PTFE	17.00 x 120.00	15.00	13,000 x g	+	25 in rack
	50750	PP / HDPE	Silicone / PTFE	30.00 x 115.00	50.00	14,000 x g	+	25 in rack

Test Tube

SPL Life Sciences provides a wide range of Test Tubes to meet various demands. Tubes are differentiated by volume, material, and sterilization method.

- Internal graduations
- Dual-position snap cap for easy handling
- No cap, non-sterile, for flow cytometry (Cat. No. 40205)
- Sterilized by E.O. gas (Cat. No. 40005, 40014, 41005, 41014)
- Irradiated by E-beam (Cat. No. 40105, 42105, 40114, 42114)
- Individually wrapped (Cat. No. 42105, 42114)
- Translucent polypropylene tubes with high chemical and thermal stability (Cat. No. 41005, 41014)
- Non-pyrogenic
- Non-cytotoxic
- DNase / RNase-free
- Human DNA-free



Test Tube

Type	Cat. No.	Material (Tube / Cap)	Total Vol. (ml)	External Dimensions d x h (mm)	RCF Rating	Sterile	Packaging
E	40005	PS / LDPE	5.00	12.00 x 75.00	1,400 x g	E.O.	25 / 500
	40105	PS / LDPE	5.00	12.00 x 75.00	1,400 x g	E-Beam	25 / 500
	42105	PS / LDPE	5.00	12.00 x 75.00	1,400 x g	E-Beam	1 / 500
□	41005	PP / LDPE	5.00	12.00 x 75.00	3,000 x g	E.O.	25 / 500
	40205	PS	5.00	12.00 x 75.00	1,400 x g	-	100 / 1,000
E	40014	PS / LDPE	14.00	17.00 x 95.40	1,400 x g	E.O.	25 / 500
	40114	PS / LDPE	14.00	17.00 x 95.40	1,400 x g	E-Beam	25 / 500
	42114	PS / LDPE	14.00	17.00 x 95.40	1,400 x g	E-Beam	1 / 500
	41014	PP / LDPE	14.00	17.00 x 95.40	3,000 x g	E.O.	25 / 500

Handling & Storage





Micro Vial

Micro Vial is designed for the storage and transportation of biological material. Every screw cap has silicone O-ring seal to ensure leak proof, providing a smooth and uniform inner surface, thus reducing the risk of contamination.

- With attached cap (Cat. No. 45115)
- With unattached cap (Cat. No. 45015, 45002)
- Without O-ring (Cat. No. 45402)



Micro Vial

Type	Cat. No.	Total Vol. (ml)	Material (Tube / Cap)	Cap Color	Bottom Type	Attached Cap	O-ring	Packaging
	45015	1.50	PP / HDPE	Green	Skirted	-	+	500 / 2,000
	45115	1.50	PP / HDPE	Green	Skirted	+	+	500 / 2,000
	45002	2.00	PP / HDPE	Green	Skirted	-	+	500 / 2,000
	45402	2.00	PP / PP	Clear	Skirted	-	-	500 / 2,000





Reinforced Tube

Reinforced Tubes are designed for Beads Beater Homogenizer as well as the storage and transportation of biological material. They are produced with high quality Polypropylene to meet the demands of high durability. In addition, Silicone O-rings are inserted into caps to prevent leakage. Reinforced Tube has two bottom types, skirted and non-skirted, and can be selected depending on the purpose.

- Autoclavable
- Non – pyrogenic
- Non – cytotoxic
- DNase / RNase – free
- Human DNA – free



Reinforced Tube

Type	Cat. No.	Total Vol. (ml)	Material (Tube / Cap)	Bottom Type	RCF rating	Sterile	Packaging
	47020	2.00	PP / HDPE	Skirted	-	+	250 / 500
	47120	2.00	PP / HDPE	Skirted	-	-	250 / 500
	47220	2.00	PP / HDPE	Non-Skirted	22,000 x g	+	250 / 500
	47320	2.00	PP / HDPE	Non-Skirted	22,000 x g	-	250 / 500

Handling & Storage

250 ml Conical Tube

250 ml Conical tube can be used in storage of samples and centrifugation of large volume samples, between 50 ml to 250 ml. The product is provided with a dedicated Styrofoam rack for user convenience.

- Tight sealing screw cap
- External graduations with marking area
- Packed in sleeves
- Polypropylene conical tubes
- Provided with a Styrofoam rack
- Sterile
- Non pyrogenic
- Non-cytotoxic
- DNase/RNase – free
- Human DNA – free



250 ml Conical Tube

Type	Cat. No.	Material (Tube / Cap)	External Dimension (mm)	Total Volume (ml)	RCF Rating	Sterile	Packaging
	558250	PP / PP	60.00 x 148.00	250.00	5,000 x g	+	6 / 54

1.5 ml Strip Tube

1.5 ml Strip Tube, available as six microcentrifuge tubes per strip, is ideal for any large-scale experiments. The strips can be cut into individual tubes, and are universally applicable to centrifugation*.

- Snap cap with tight sealing
- External graduations with marking area
- Central part in cap enough to be penetrated by syringe needle
- Autoclavable

- Non-pyrogenic
- Non-cytotoxic
- DNase / RNase-free
- Human DNA-free



1.5 ml Strip Tube

Type	Cat. No.	Material	Color	Total Vol. (ml)	RCF Rating	Sterile	Packaging
	60615	PP	Clear	1.50	30,000 x g	-	80 / 800
	60715	PP	Clear	1.50	30,000 x g	+	40 / 800

* 1.5 ml Strip Tube may be restrictedly compatible with rotors, depending on the types of rotor being used for centrifugation. Compatibility test is highly recommended. (Compatible with most 24-, 30-hole rotors, and few 18-hole rotors)



Protein Safe

The surface of common plastic tubes can occur protein adsorption, resulting in fatal losses, which can affect experimental results. Protein Safe, made from a special polymer, prevents loss of protein in solution by minimizing adsorption on the inner surface of tubes. Thus, it shows excellent recovery even with extremely low concentration protein samples.

- Smooth opening and tight sealing
- Imprinted external graduations with marking area
- Central part in cap enough to be penetrated by syringe needle
- Non-pyrogenic
- Non-cytotoxic
- DNase / RNase-free
- Human DNA-free



Protein Safe

Type	Cat. No.	Material	Total Vol. (ml)	RCF Rating	Sterile	Packaging
	65015	PP	1.50	30,000 x g	-	50 / 100
	65020	PP	2.00	20,000 x g	-	50 / 100

Handling & Storage

Microcentrifuge Tube

Smooth opening and tight sealing are unique features of SPL's Microcentrifuge Tubes. Microcentrifuge Tubes are produced with high-quality, high-chemical resistance, and high-strength polypropylene to fulfill various needs of applications in molecular biology.

SPL microcentrifuge tubes come in three sizes: 1.5 ml, 1.7 ml, and 2.0 ml. These tubes not only differ in size but each tube also serves a distinct purpose. Please refer to the specific descriptions below to select the most appropriate microcentrifuge tubes for your use.

- External graduations with marking area
- Autoclavable
- Snap cap opens smoothly but seals tight
- High chemical resistance
- Piercing port in the center of the cap is penetrable by syringe needles (1.5 ml, 2.0 ml)
- Has excellent visibility (1.7 ml)
- 5 colors : Blue, Green, Orange, Pink, Yellow (Cat. No. 61015, 61017)
- Amber Max offers more powerful light shielding. (Cat. No. 64015, 64020)
- Non-pyrogenic
- Non-cytotoxic
- DNase / RNase-free
- Human DNA-free



continued on next page



Microcentrifuge Tube

Type	Cat. No.	Material	Color	Total Vol. (ml)	RCF Rating	Sterile	Packaging
	60015	PP	Clear	1.50	30,000 x g	-	500 / 1,000 / 5,000
	60115	PP	Clear	1.50	30,000 x g	+	250 / 1,000 / 5,000
	61015	PP	5 colors	1.50	30,000 x g	-	200 / 1,000 / 5,000
	62015	PP	Amber	1.50	30,000 x g	-	200 / 1,000 / 5,000
	64015	PP	Amber Max	1.50	30,000 x g	-	200 / 1,000
	60017	PP	Clear	1.70	25,000 x g	-	500 / 1,000 / 5,000
	60117	PP	Clear	1.70	25,000 x g	+	250 / 1,000 / 5,000
	61017	PP	5 colors	1.70	25,000 x g	-	200 / 1,000 / 5,000
	62017	PP	Amber	1.70	25,000 x g	-	500 / 1,000 / 5,000
	61020	PP	Clear	2.00	20,000 x g	-	500 / 1,000 / 5,000
	61120	PP	Clear	2.00	20,000 x g	+	250 / 1,000 / 5,000
	64020	PP	Amber Max	2.00	20,000 x g	-	200 / 1,000

Handling & Storage

4-3. Racks & Boxes

SPL is also dedicated to developing and manufacturing various products for sample storage.



Conical Tube Rack I

SPL Conical Tube Rack I is economical and alternative solution for stainless wire racks or other plastic racks. Racks are uniquely designed for handling and storing 25 conical tubes (i.e., 15 ml or 50 ml).

- Excellent stackability
- Numeric labeling



Conical Tube Rack I

Type	Cat. No.	Material	Description	Packaging
	52015	PP	25 Holes for 15 ml tubes	20
	52050	PP	25 Holes for 50 ml tubes	20



Conical Tube Rack II

SPL Conical Tube Rack II is economical and alternative solution for stainless wire racks or other plastic racks. Racks are ergonomically designed for easier handling and storing 25 conical tubes (i.e., 15 or 50 ml).

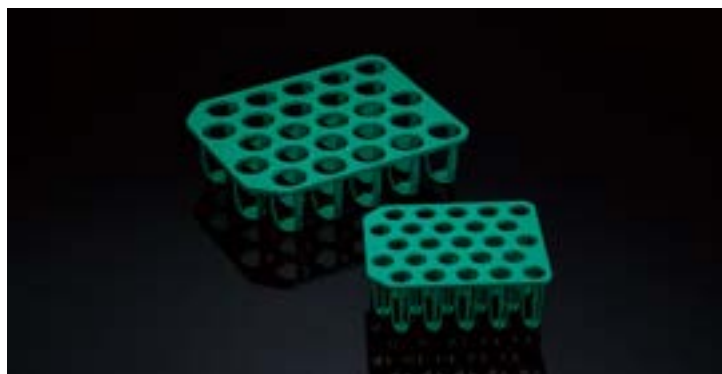
- Numeric labeling



Conical Tube Rack II

Type	Cat. No.	Material	Description	Packaging
	52115	PP	25 Holes for 15 ml tubes	20
	52150	PP	25 Holes for 50 ml tubes	20



Snap Tube Rack

SPL Snap Tube Racks are designed identical to SPL Conical Tube Racks, with the exception of inner dimensions and enhanced structural integrity. The racks are uniquely designed for handling and storage of 25 snap tubes (i.e., 15 ml or 50 ml).

- Excellent stackability
- Numeric labeling
- 1 colors: Blue



Snap Tube Rack

Type	Cat. No.	Material	Description	Packaging
	53015	PP	25 Holes for 5 & 15 ml tubes	50
	53050	PP	25 Holes for 50 ml tubes	20

2well Conical Tube Rack

2well Conical Tube Racks maximize space with the flexibility to hold two type tubes (15 / 50 ml) in one configurable rack and they are also suitable for simple handling such as weighing.

- Hold 1 x 50 ml and 1 x 15 ml Conical Tubes
- Easy to grip by hand
- Slides smoothly across the bench top
- Assorted colors: Black, White, Lime, and Green



2well Conical Tube Rack

Type	Cat. No.	Material	Color	Description	Packaging
	52202	PP	4 colors	2 Holes for 15 & 50 ml tubes	20

Handling & Storage

5 ml Tube Rack

SPL 5 ml Tube Rack, which is designed for 5 ml centrifuge tubes, is specialized for easy viewing of tube contents. 5 ml Tube Rack is made of Polypropylene (PP) and provides high level of chemical and heat resistance. This rack will be also suitable to accommodate other size tubes with 15 ml Conical Tubes. SPL 5 ml Tube Rack stores up to 12 tubes for bench-top use, storage or transport of samples.

- Stores tubes in compact arrangement (2 x 6 array)
- Numeric positions for easy sample identification
- Assorted colors (White, Black, Purple)
- Autoclavable
- Stackable
- 5 ml Tube Rack is only available for conical type tubes (not for skirted)



5 ml Tube Rack

Type	Cat. No.	Material	Description	Packaging
	61012	PP	2 x 6 (12 Holes)	12

Stacker Microtube Rack

SPL Stacker Microtube Racks are uniquely designed for handling and storage of Microcentrifuge Tubes.

- Stackable feature for space saving
- 5 colors: Pink, Yellow, Green, Orange, Blue
- Non-autoclavable



Stacker Microtube Rack

Type	Cat. No.	Material	Description	Packaging
	61048	ABS	6 x 8 (48 Holes)	10

Microtube Rack

SPL Microtube Racks are designed for handling and storage of Microcentrifuge Tubes.

- Numeric labeling
- 5 colors: White, Blue, Green, Red, Purple
- Autoclavable



Microtube Rack

Type	Cat. No.	Material	Description	Packaging
	61080	PP	5 x 16 (80 Holes)	25

Standing Microtube Rack

1.5 ml arch-shaped Strip Tube Rack not only facilitates efficient storage and handling but also ensures test samples are easily observable and directly vortexing on the rack.

- Stackable feature for space saving
- Colors: Green
- Non-autoclavable



Standing Microtube Rack

Type	Cat. No.	Material	Description	Packaging
	61024	PS	6 x 4 (24 Holes)	10

PCR Tube Rack

SPL PCR Tube Racks are specially designed to handle and store PCR Tubes or Strips.

- 5 colors: White, Blue, Green, Orange, Purple
- Autoclavable



PCR Tube Rack

Type	Cat. No.	Material	Description	Packaging
	80096	PP	8 x 12 (96 Holes)	10

Handling & Storage





Storage Box

SPL Storage Boxes are designed to hold microtubes and vials in a wide temperature ranges. Two different sizes are available for various purposes.

- Temperature range: -70 ~ 140°C
- 5 colors: Blue, Green, Orange, Pink, Purple (Cat. No. 81100)
- Hinged lid type (Cat. No. 80100, 81100, 84100)
- Autoclavable
- Amber type (Cat. No. 84100)



Storage Box

Type	Cat. No.	Material	Description	Feature	Packaging
	80100	PP	Natural Color	10 x 10 (100 Holes)	30
	81100	PP	5 Colors	10 x 10 (100 Holes)	30
	84100	PP	Amber	10 x 10 (100 Holes)	6
	81081	PP	Natural Color	9 x 9 (81 Holes)	40

Conical Tube Storage Box



Conical Tube Storage Box can save the space when using refrigerators and deep freezers.

- Temperature range: -80°C ~ RT
- Moisture repellent coating Cardboard Box
- 50 ml Conical Tubes, Snap Tubes are available (Cat. No. 80116)
- 15 ml Conical Tubes, Snap Tubes are available (Cat. No. 80136)



continued on next page

Conical Tube Storage Box

Type	Cat. No.	Material	Feature	Description	Packaging
	80116	Cardboard	50 ml Tubes	4 x 4 (16 Holes)	12
	80136	Cardboard	15 ml Tubes	6 x 6 (36 Holes)	12

25 ml Tube Storage Box

25 ml Tube Storage Box can save the space when using refrigerators and deep freezers.

- Temperature range: -80°C ~ RT
- Moisture repellent coating Cardboard Box

**25 ml Tube Storage Box**

Type	Cat. No.	Material	Feature	Description	Packaging
	80216	Cardboard	25 ml Tubes	4 x 4 (16 Holes)	8

5 ml Tube Storage Box

5 ml Tube Storage Box can save the space when using refrigerators and deep freezers.

- Temperature range: -80°C ~ RT
- Moisture repellent coating Cardboard Box

**5 ml Tube Storage Box**

Type	Cat. No.	Material	Feature	Description	Packaging
	80236	Cardboard	5 ml Tubes	6 x 6 (36 Holes)	8

Handling & Storage

4-4. Bottles

Most biological samples and reagents should be stored and maintained in appropriate conditions depending on the purpose of your experiments. Our products are not solely designed to store your liquid samples, but to provide extra features useful in experiments, such as centrifugation-feasibility and light shielding function. Therefore, choosing appropriate tubes or bottles will allow you store your liquid samples and conduct experiments accordingly.

1,000 ml Wide Mouth Bottle

NEW











Wide-Mouth Bottle (HDPE)

SPL Bottles are durable bottles for storing and handling liquid / solid forms of samples and chemicals. Various sizes are available.

- Volumes range from 20 to 1,000 ml
- 250 ml bottles are applicable for centrifugation (RCF 4,000 x g)
- Caution: Not designed for use under full vacuum or high pressure (Pressure limit: -12.5 cmHg at room temp.)



Wide-Mouth Bottle (HDPE)

Type	Cat. No.	Material (Bottle / Cap)	Total Vol. (ml)	Closure Size (mm)	Packaging
	59020	HDPE / PP	20.00	32.00	1,000
	59030	HDPE / PP	30.00	32.00	1,000
	59031	HDPE / PP	30.00	32.00	12 / 72
	59060	HDPE / PP	60.00	32.00	1,000
	59125	HDPE / PP	125.00	42.50	500
	59250	HDPE / PP	250.00	46.20	72
	59500	HDPE / PP	500.00	57.20	48
	59000	HDPE / PP	1,000.00	66.00	6 / 24

Handling & Storage







Wide-Mouth Bottle (Amber)

SPL Bottles are durable bottles for storing and handling liquid / solid forms of samples and chemicals. Various sizes are available.

- Useful for light-sensitive materials
- Volumes range from 20 to 1,000 ml
- 250 ml bottles are applicable for centrifugation (RCF 4,000 x g)
- Caution: Not designed for use under full vacuum or high pressure (Pressure limit: -12.5 cmHg at room temp.)



Wide-Mouth Bottle (Amber)

Type	Cat. No.	Material (Bottle / Cap)	Total Vol. (ml)	Closure Size (mm)	Packaging
	57020	HDPE / PP	20.00	32.00	1,000
	57030	HDPE / PP	30.00	32.00	1,000
	57060	HDPE / PP	60.00	32.00	1,000
	57125	HDPE / PP	125.00	42.50	500
	57250	HDPE / PP	250.00	46.20	72
	57500	HDPE / PP	500.00	57.20	48
	57000	HDPE / PP	1,000.00	66.00	6 / 24









Wide-Mouth Bottle (PP)

SPL Bottles are durable bottles for storing and handling liquid / solid forms of samples and chemicals. Various sizes are available.

- Volumes range from 5 to 1,000 ml
- 250 ml bottles are applicable for centrifugation (RCF 4,000 x g)
- Colored caps available for 5 ml bottles: Blue, Green, Red, Yellow (Cat. No. 58005)
- Autoclavable
- Caution: Not designed for use under full vacuum or high pressure (Pressure limit: -12.5 cmHg at room temp.)



Wide-Mouth Bottle (PP)

Type	Cat. No.	Material (Bottle / Cap)	Total Vol. (ml)	Closure Size (mm)	Packaging
	58005	PP / PP	5.00	18.00	1,000
	58020	PP / PP	20.00	32.00	1,000
	58030	PP / PP	30.00	32.00	1,000
	58031	PP / PP	30.00	32.00	12 / 72
	58060	PP / PP	60.00	32.00	1,000
	58125	PP / PP	125.00	42.50	500
	58250	PP / PP	250.00	46.20	72
	58500	PP / PP	500.00	57.20	48
	58000	PP / PP	1,000.00	66.00	6 / 24

Handling & Storage

Media Bottle

SPL Life Sciences media bottles, composed of high-strength plastic material, are intended for storing and transporting general reagents and cell culture reagents. The square-shaped bottles are designed to maximize space saving, durability, strength, and clarity.







The bottles are available as follow: 60 ml, 125 ml, 250 ml, 500 ml, and 1,000 ml.

They are shrink-wrapped in a double-walled corrugated paper boxes and thoroughly sterilized for best quality.

- Molded-in graduation scales
- Shrink-wrap tray modules
- Non-pyrogenic
- Non-cytotoxic
- Non-hemolytic
- DNase / RNase-free
- Human DNA-free



Media Bottle

Type	Cat. No.	Material (Bottle / Cap)	Total Vol. (ml)	Sterile	Packaging
	56060	PET / HDPE	60.00	+	25 / 200
	56061	PETG / HDPE	60.00	+	25 / 200
	56125	PET / HDPE	125.00	+	24 / 96
	56250	PET / HDPE	250.00	+	30 / 60
	56500	PET / HDPE	500.00	+	24 / 48
	56000	PET / HDPE	1,000.00	+	12 / 24









Narrow-Mouth Bottle (HDPE)

SPL Narrow-Mouth Bottles are durable bottles for storing and handling liquid / solid forms of samples and chemicals. Various sizes are available.

- Volumes range from 4 to 1,000 ml
- Caution: Not designed for use under full vacuum or high pressure (Pressure limit: -12.5 cmHg at room temp.)

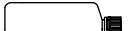

Narrow-Mouth Bottle (HDPE)

Type	Cat. No.	Material (Bottle / Cap)	Total Vol. (ml)	Packaging
	516001	HDPE / PP	4.00	12 / 72
	516002	HDPE / PP	8.00	12 / 72
	516003	HDPE / PP	15.00	12 / 72
	516004	HDPE / PP	30.00	12 / 72
	516005	HDPE / PP	60.00	12 / 72
	516006	HDPE / PP	125.00	12 / 72
	516007	HDPE / PP	250.00	12 / 72
	516008	HDPE / PP	500.00	12 / 48
	516009	HDPE / PP	1,000.00	6 / 24

Handling & Storage









Narrow-Mouth Bottle (Amber)

SPL Narrow-Mouth Bottles are durable bottles for storing and handling liquid / solid forms of samples and chemicals. Various sizes are available.

- Useful for light-sensitive materials
- Volumes range from 4 to 1,000 ml
- Caution: Not designed for use under full vacuum or high pressure (Pressure limit: -12.5 cmHg at room temp.)



Narrow-Mouth Bottle (Amber)

Type	Cat. No.	Material (Bottle / Cap)	Total Vol. (ml)	Packaging
	516010	HDPE / PP	4.00	12 / 72
	516011	HDPE / PP	8.00	12 / 72
	516012	HDPE / PP	15.00	12 / 72
	516013	HDPE / PP	30.00	12 / 72
	516014	HDPE / PP	60.00	12 / 72
	516015	HDPE / PP	125.00	12 / 72
	516016	HDPE / PP	250.00	12 / 72
	516017	HDPE / PP	500.00	12 / 48
	516018	HDPE / PP	1,000.00	6 / 24









Narrow-Mouth Bottle (PP)

SPL Narrow-Mouth Bottles are durable bottles for storing and handling liquid / solid forms of samples and chemicals. Various sizes are available.

- Volumes range from 4 to 2,000 ml
- Autoclavable

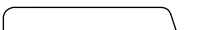

Narrow-Mouth Bottle (PP)

Type	Cat. No.	Material (Bottle / Cap)	Total Vol. (ml)	Packaging
	516019	PP / PP	4.00	12 / 72
	516020	PP / PP	8.00	12 / 72
	516021	PP / PP	15.00	12 / 72
	516022	PP / PP	30.00	12 / 72
	516023	PP / PP	60.00	12 / 72
	516024	PP / PP	125.00	12 / 72
	516025	PP / PP	250.00	12 / 72
	516026	PP / PP	500.00	12 / 48
	516027	PP / PP	1,000.00	6 / 24
	516028	PP / PP	2,000.00	1 / 6

Handling & Storage



Biotainer

The Biotainer is manufactured using transparent Polycarbonate and can store large volumes of samples. Various samples can be stored due to the high durability of the Biotainer and can be used at -80 ~ 100°C. And silicon pad is inserted inside of the cap to effectively prevent leakage.

- Autoclavable
- Non-pyrogenic
- Non-cytotoxic
- DNase / RNase-free
- Human DNA-free



Biotainer

Type	Cat. No.	Material (Bottle / Cap)	Diameter x Height (mm)	Color	Total Vol. (ml)	Sterile	Packaging
	562000	PC / PP	110.00 x 268.00	Clear	2,000.00	+	4 / 20
	565000	PC / PP	166.00 x 299.00	Clear	5,000.00	+	1 / 6



Storage Bottle

Storage Bottle can be stored various types of aqueous solutions, such as media, buffer and etc. Ergonomically designed bottle is easy to hold with one hand that making handling easier.

- 250 ml, 500 ml Storage Bottle can be used with Bottle Top Filter (Cat. No. 508150/508151/508500/508501)
- 1,000 ml Storage Bottle (Cat. No. 551000): For storage use only
- Non-pyrogenic
- Non-cytotoxic
- Non-Hemolytic
- DNase / RNase-free
- Human DNA-free



Storage Bottle

Type	Cat. No.	Material (Bottle / Cap)	Total Vol. (ml)	Sterile	Packaging
	550250	PS / PP	250.00	+	2 / 24
	550500	PS / PP	500.00	+	2 / 24
	551000	PS / PP	1,000.00	+	2 / 24

Port Cap

The product is individually packaged and can be ready to use in an aseptic environment. By connecting a silicone tube to the port, liquid can be transported in a closed system. The inside of the cap is designed to be GL45, so it is applicable to Glass Bottles or SPL Storage Bottles.

- Easy Silicone Tube insertion
- Available Silicone Tube internal diameter (I.D): 6.0 ~ 9.0 mm
- Simplified transfer of liquids within closed and sterile systems
- Non-pyrogenic
- Non-cytotoxic
- DNase / RNase – free
- Human DNA – free



Port Cap

Type	Cat. No.	Material	Port	Closure Size	Sterile	Packaging
	99001	PP	2	GL45	+	1 / 10

Handling & Storage

4-5. Storage & Accessories

SPL is also dedicated to developing and manufacturing various products for sample storage.

Deep Well Plate



SPL Deep Well Plates are suitable for various experiments in the field of biology such as HTS applicable assay, sample storage, cell culture, and more. Deep Well Plates which are made of high quality polypropylene display high chemical resistance to most polar organic solvents, acid and weak bases. Deep Well Plates are designed with numbers and alphabets on the top to allow for easy sampling.

- Easy to transport and storage, layered (stacking)
- For multi-channel pipette and automatic equipment
- Numeric labeling
- Available storage at -80°C to 121°C
- 8well Plate (Cat. No. 34008, 34108)

- Non-pyrogenic
- DNase / RNase-free
- Human DNA-free



Deep Well Plate

Type	Cat. No.	Material	Configuration	External Dimensions w x l x h (mm)	Bottom Type	Total Vol. (ml)	Sterile	Packaging
	34008	PP	8well	127.60 x 85.40 x 44.00	V	25.00	+	5 / 25
	34108	PP	8well	127.60 x 85.40 x 44.00	V	25.00	-	5 / 25
	34496	PP	96well	127.60 x 85.40 x 30.00	V	0.80	+	5 / 25
	34596	PP	96well	127.60 x 85.40 x 30.00	V	0.80	-	5 / 25
	34696	PP	96well	127.60 x 85.40 x 44.00	U	2.00	+	5 / 25
	34796	PP	96well	127.60 x 85.40 x 44.00	U	2.00	-	5 / 25



Sealing Mat

Sealing Mat is compatible with most 96well plate and can be used for sample storage. Sealing Mat is easy and convenient to attach and detach and can be used in conditions of -80 to 121 °C. In addition, It has excellent resistance to solvent such as DMSO and can be reused.

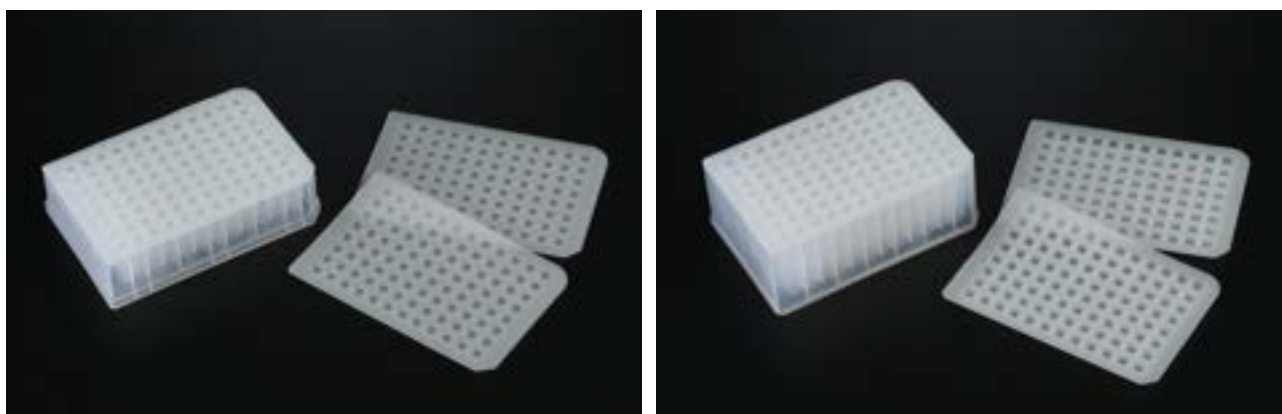
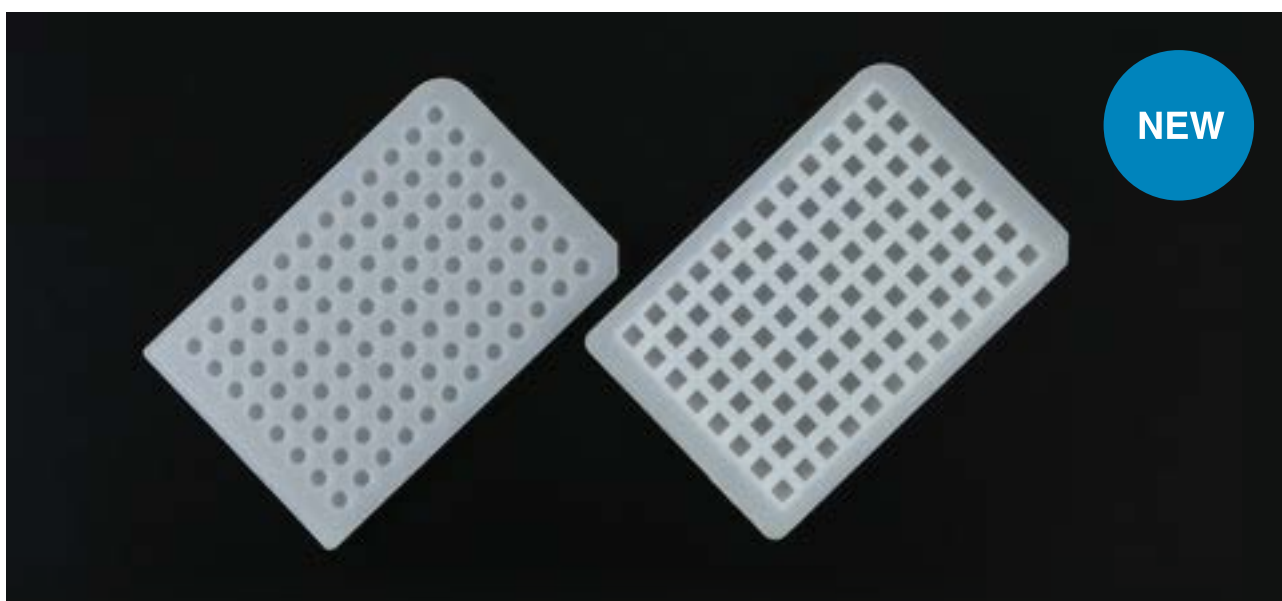
- Autoclavable
- Working temperature range: -80 ~ 121 °C
- Solvent resistant
- Reusable



Sealing Mat

Type	Cat. No.	Material	Configuration	External Dimensions w x l x h (mm)	Sterile	Packaging
	96006	Silicone	Round well	123.9 x 81.9	-	10 / 30
	96007	Silicone	Square Well	123.9 x 81.9	-	10 / 30

Handling & Storage

Deep Well Reservoir

SPL Deep Well Reservoir can hold large volume solutions and is easy to handle. Deep Well Reservoir is a 2well reservoir made of high quality polypropylene (PP), that can store a total of 300 ml (150 ml / well) in one product.

The scales are molded at 50 ml intervals. Applicable to automation equipment, the advantages of holding large volumes of solutions can increase automatic processing time. It can be selected according to sterilized or non-sterilized.

- Large volume of solution can be contained and layered (stacking)
- Design for all types of multi-pipettes
- Applicable to automation equipment



Deep Well Reservoir

Type	Cat. No.	Material	External Dimension w X l X h (mm)	Bottom Type	Vol.(ml)	Sterile	Packaging
	34002	PP	127.60 x 85.40 x 40.00	Flat	150	+	5 / 25
	34102	PP	127.60 x 85.40 x 40.00	Flat	150	-	5 / 25





Reservoir

Sloped bottoms of SPL Reservoirs are useful for filling multichannel-pipette during both cell culture and immunoassay experiments.

- Supplied non-sterile in packs of 20 (Cat. No. 23001)
- Notched volume label (Cat. No.22050, 23050, 22001, 23001)



Reservoir

Type	Cat. No.	Material	Color	Design	Channel	Working Vol. (ml)	Sterile	Packaging
	22001	PS	White	Sloped Bottom	1	100.00	+	1 / 50
	23001	PS	White	Sloped Bottom	1	100.00	-	20 / 100
	22050	PS	White	Sloped Bottom	1	50.00	+	1 / 50
	23050	PS	White	Sloped Bottom	1	50.00	+	5 / 100
	21002	PS	White	Sloped Bottom	2	25.00	+	1 / 50
	21102	PS	White	Sloped Bottom	2	25.00	+	5 / 100
	21008	PS	White	Sloped Bottom	8	7.00	+	1 / 100
	21012	PS	White	Sloped Bottom	12	4.00	+	1 / 100





Storage Plate 96well

SPL Storage Plates are designed for storage of biological samples and chemicals.

- Storage of biological sample and chemicals in small quantity
- Temperature range: -70 ~ 121°C (Cat. No. 34396, 36396, 336396)
- Chemically resistant to organic solvents, such as weak acids and weak bases. (Cat. No. 34396, 36396, 336396)
- With Lid (Cat. No. 34396, 36396)
- Without Lid (Cat. No. 336396, 336196)



Storage Plate 96well

Type	Cat. No.	Material	External Dimensions w x l x h (mm)	Bottom Type	Color	Total Vol. (ml)	Lid	Sterile	Packaging
	34396	PP	85.40 x 127.60 x 14.40	Round	Clear	0.30	+	-	10 / 100
	36396	PP	85.40 x 127.60 x 14.40	Conical	Clear	0.32	+	-	10 / 100
	336396	PP	85.40 x 127.60 x 14.40	Conical	Clear	0.32	-	-	10 / 100
	336196	PS	85.40 x 127.60 x 14.40	Conical	Clear	0.32	-	-	10 / 100

Handling & Storage

Omni Box

Omni Boxes of SPL enable simple and convenient storage of small experimental equipment in a single container.

- For storing magnetic bars, tubing and etc



Omni Box

Type	Cat. No.	Material	Dimensions w x l x h (mm)	Packaging
	80010	PS	97.00 x 183.00 x 33.00	1

Autoclaving Jar

Autoclaving Jars are containers suitable for autoclaving small plastic-wares that require sterilization.

- Autoclavable



Autoclaving Jar

Type	Cat. No.	Material	Container Style (mm)	Internal Dimensions d x h (mm)	Packaging
	310123	PP	120.00 x 80.00	103.00 x 78.60	20

MOUZIP®

MOUZIP® is a unique device that serves as a complete testing bench for a variety of mouse experiments, composed of an experimental mat that absorbs spilled liquids and a paper disposal case that wraps the mouse cadaver for ethical handling, storing, and disposing.

- The top side of the mat efficiently absorbs any excess liquids during the experiment, while the waterproof bottom maintains hygienic conditions.
- The paper case connected to the mat is folded up in a triangular coffin-like structure to enable ethical storage and hygienic disposal of cadaver after experiments.



MOUZIP®

Type	Cat. No.	Material (Outer / Inner)	Cover Dimensions (cm)	Mat Dimensions (cm)	Packaging
	82101	Kraft / Fiber mat	13.00 x 24.00	103.00 x 78.60	20

25 ml Tube Adapter

25 ml Tube Adapter for 50 ml centrifuge rotors.

- Excellent durability
- 25 ml Tube Adapter is only available for conical type tubes (not for skirted)

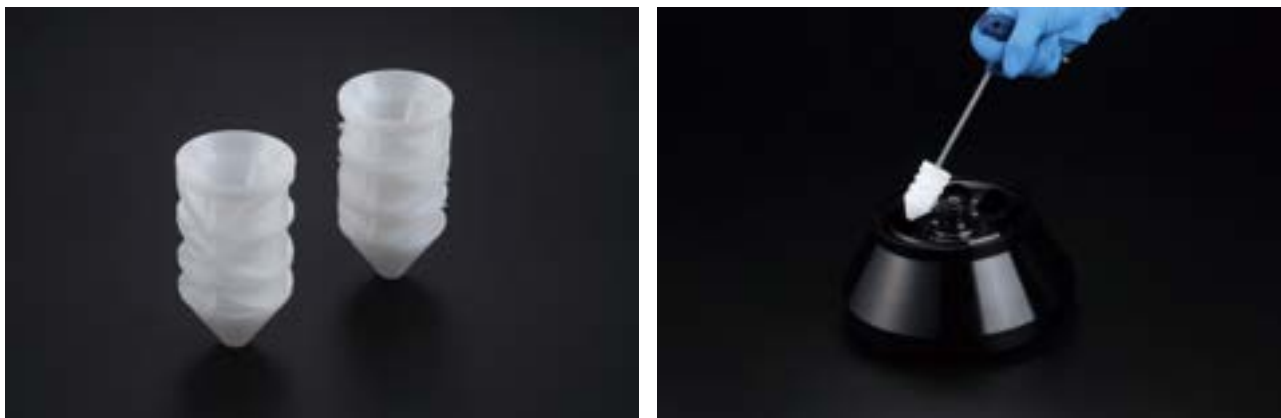

25 ml Tube Adapter

Type	Cat. No.	Material	External Dimensions d x h (mm)	RCF rating	Packaging
	52025	Acetal	28.50 x 52.00	18,000 x g	6

5 ml Snap Tube Adapter

SPL 5 ml Snap Tube Adapter is designed for 15 ml centrifuge rotors.

- Excellent durability
- 5 ml Snap Tube Adapter is only available for conical type tubes (not for skirted)

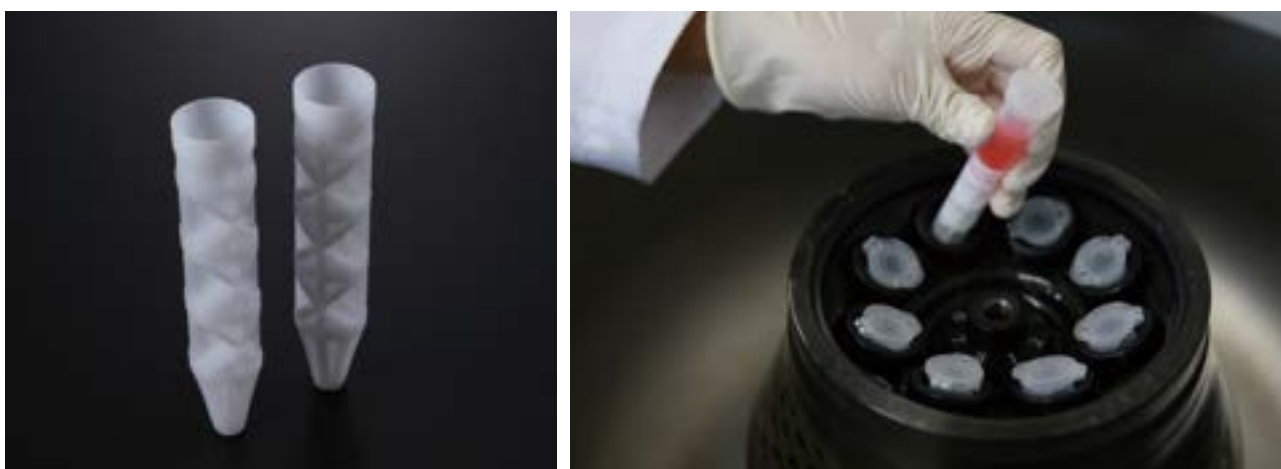

5 ml Snap Tube Adapter

Type	Cat. No.	Material	External Dimensions d x h (mm)	RCF rating	Packaging
	52005	Acetal	16.60 x 78.24	25,000 x g	10

Handling & Storage



Label Protection Tape

Label Protection Tape protects labels in harsh or outdoor environments, against water, UV, chemicals, and abrasion. It is available for all products and you can easily distinguish samples in three colors on the border.

- Prevent evaporation
- 3 colors: Red, Green, Blue
- Working temperature range: -20°C ~ 100°C
- Thickness: 0.5 mm
- Non-sterile



Label Protection Tape

Type	Cat. No.	Material	Dimensions w x l (mm)	Color	Packaging
	96001	PET	25.00 x 85.00	Red	3,000 ea / roll
	96002	PET	25.00 x 85.00	Green	3,000 ea / roll
	96003	PET	25.00 x 85.00	Blue	3,000 ea / roll



Glove (Safe Guard)

SPL Safe Guard protects against various harmful sources such as chemicals, solvents, microorganism, and physical abrasion etc. and reduces the risk of contamination. SPL Safe Guard, made of latex or nitrile, offers strong durability and comfortable wearing.

- Comfortably fit and increased flexibility
- Excellent durability
- Powder Free
- Meet or exceed ASTM D 3578 (Cat. No. G9100, G9110, G9120, G9130)
- Meet or exceed ASTM D 6319 (Cat. No. G9200, G9210, G9220, G9230)



Glove (Safe Guard)

Type	Cat. No.	Material	Size	Color	Packaging
	G9100	Latex	Extra Small	Natural	100
	G9110	Latex	Small	Natural	100
	G9120	Latex	Medium	Natural	100
	G9130	Latex	Large	Natural	100
	G9200	Nitrile	Extra Small	Blue	100
	G9210	Nitrile	Small	Blue	100
	G9220	Nitrile	Medium	Blue	100
	G9230	Nitrile	Large	Blue	100

Handling & Storage



Disposable Tweezers

Disposable Tweezers are made of clean and durable polystyrene material, and it is four times lighter than conventional metal tweezers, reducing the strain on the wrist during the experiment. It also minimizes cross-contamination of the sample. The sharp type is suitable for handling fine samples, and the broad type is optimized for handling cover glass or plastic coverslip.

- Sharp type: For fine sample handling (Cat. No. 90060)
- Broad type: For cover glasses / coverslips (Cat. No. 90061)
- Individual packaging



Disposable Tweezers

Type	Cat. No.	Material	Type	Length (mm)	Sterile	Packaging
	90060	PS	Sharp	123.00	+	1 / 50
	90061	PS	Broad	123.00	+	1 / 50



Water Sample Bottle

SPL Water Sample Bottles are suitable for environmental hygiene analysis.

- Easy to carry
- Reduced volume for storage



Water Sample Bottle

Type	Cat. No.	Material	External Dimensions w x l x h (mm)	Total Vol. (L)	Sterile	Packaging
	410011	PE	79.70 x 130.80 x 160.90	1.00	+	1 / 150
	410012	PE	97.90 x 162.70 x 207.10	2.00	+	1 / 100
	410014	PE	127.00 x 204.20 x 260.40	4.00	+	1 / 65



Biohazard Bag

Biohazard Bag is designed for the safe storage, transportation, and disposal of biohazardous waste. The biohazard Bag is made of High Density Polyethylene and autoclave is possible, which ensure safely dispose of waste.

- Thickness: 0.05 mm
- 3 different sizes
- Autoclavable
- Disposable



Biohazard Bag

Type	Cat. No.	Material	Dimension (cm)	Packaging
	98000	HDPE	30.00 x 45.00	100
	98001	HDPE	40.00 x 65.00	100
	98002	HDPE	60.00 x 90.00	100

Handling & Storage

Silicone Tubing

Silicone tubes are manufactured by General, Laboratory, and Vacuum. General silicone tubing is characterized by translucency and high heat resistance, so it can be universally used in extreme environments. Laboratory silicone tubing is platinum-cured and recommended for use in pharmaceutical and biotechnology applications. Vacuum silicone tubing is thick, so it is not adsorbed by pressure and can be used in extreme environments. If there is a desired size or cut length other than the item, please contact us with a custom product and we will respond.

- Temperature range: - 60 ~ 230°C
- Autoclavable
- Platinum-cured silicone (Laboratory)
- Low volatility, abrasion resistance, yellowing resistance (Laboratory)
- FDA 21 CFR 177.2600

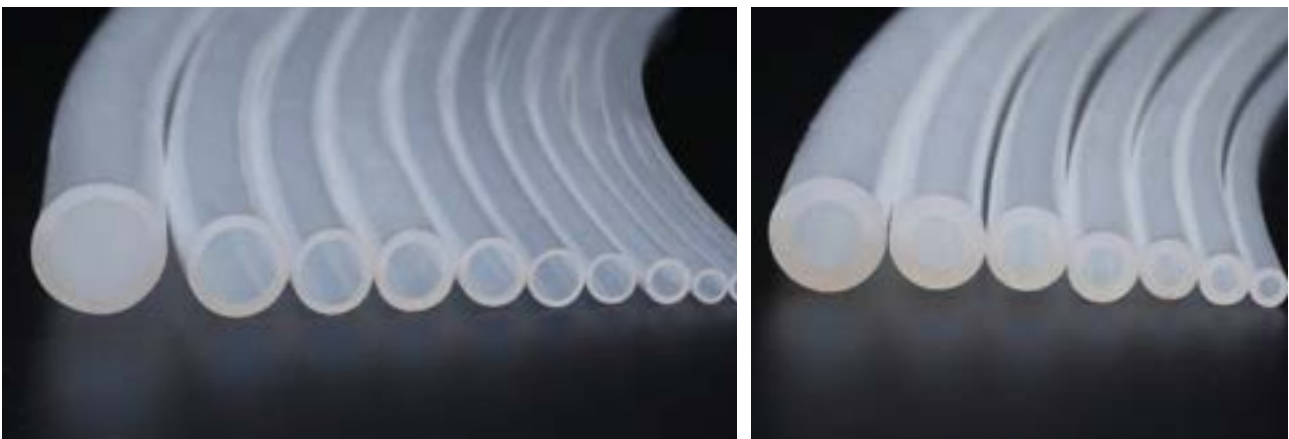

continued on next page

Silicone Tubing

Type	Cat. No.	Materials	Type	Dimensions I.D x O.D (mm)	Sterile	Packaging
⊙	98101	Pure silicone rubber	General	1.50 x 2.50	-	10 m
⊙	98102	Pure silicone rubber	General	2.00 x 3.00	-	10 m
⊙	98103	Pure silicone rubber	General	3.00 x 4.50	-	10 m
⊙	98104	Pure silicone rubber	General	4.00 x 5.50	-	10 m
⊙	98105	Pure silicone rubber	General	5.00 x 7.00	-	10 m
⊙	98106	Pure silicone rubber	General	6.00 x 8.00	-	10 m
⊙	98107	Pure silicone rubber	General	7.00 x 9.00	-	10 m
⊙	98108	Pure silicone rubber	General	8.00 x 11.00	-	10 m
⊙	98109	Pure silicone rubber	General	9.00 x 12.00	-	10 m
⊙	98110	Pure silicone rubber	General	10.00 x 13.00	-	10 m
⊙	98112	Pure silicone rubber	General	12.00 x 16.00	-	10 m
⊙	98115	Pure silicone rubber	General	15.00 x 20.00	-	10 m
⊙	98201	Platinum-Cured silicone rubber	Laboratory	1.50 x 2.50	-	10 m
⊙	98202	Platinum-Cured silicone rubber	Laboratory	2.00 x 3.00	-	10 m
⊙	98203	Platinum-Cured silicone rubber	Laboratory	3.00 x 4.50	-	10 m
⊙	98204	Platinum-Cured silicone rubber	Laboratory	4.00 x 5.50	-	10 m
⊙	98205	Platinum-Cured silicone rubber	Laboratory	5.00 x 7.00	-	10 m
⊙	98206	Platinum-Cured silicone rubber	Laboratory	6.00 x 8.00	-	10 m
⊙	98207	Platinum-Cured silicone rubber	Laboratory	7.00 x 9.00	-	10 m
⊙	98208	Platinum-Cured silicone rubber	Laboratory	8.00 x 11.00	-	10 m
⊙	98209	Platinum-Cured silicone rubber	Laboratory	9.00 x 12.00	-	10 m
⊙	98210	Platinum-Cured silicone rubber	Laboratory	10.00 x 13.00	-	10 m
⊙	98212	Platinum-Cured silicone rubber	Laboratory	12.00 x 16.00	-	10 m
⊙	98215	Platinum-Cured silicone rubber	Laboratory	15.00 x 20.00	-	10 m
⊙	98303	Pure silicone rubber	Vacuum	3.00 x 6.00	-	10 m
⊙	98304	Pure silicone rubber	Vacuum	4.00 x 8.00	-	10 m
⊙	98305	Pure silicone rubber	Vacuum	5.00 x 9.00	-	10 m
⊙	98306	Pure silicone rubber	Vacuum	6.00 x 11.00	-	10 m
⊙	98307	Pure silicone rubber	Vacuum	7.00 x 13.00	-	10 m
⊙	98308	Pure silicone rubber	Vacuum	8.00 x 15.00	-	10 m
⊙	98310	Pure silicone rubber	Vacuum	10.00 x 18.00	-	10 m

Plant & Insect Culture

SPL Life Sciences provides a wide range of plant culture products. Our products are manufactured under strict quality control system to comply with customer demands. Also we provide a unique range of insect breeding containers to enable researchers to select the right products for better breeding solutions.

5-1. Plant Culture 160

Incu Tissue	161
Plant Culture Dish	162
Plant Culture Bottle I	163
Plant Culture Bottle II.....	163
Phytohealth.....	163
AraHarvest.....	164

5-2. Insect Culture 165

Insect Breeding Dish & Jar.....	165
Insect Breeding Box.....	166
Drosophila Vials.....	167
Drosophila Vial Plugs.....	167

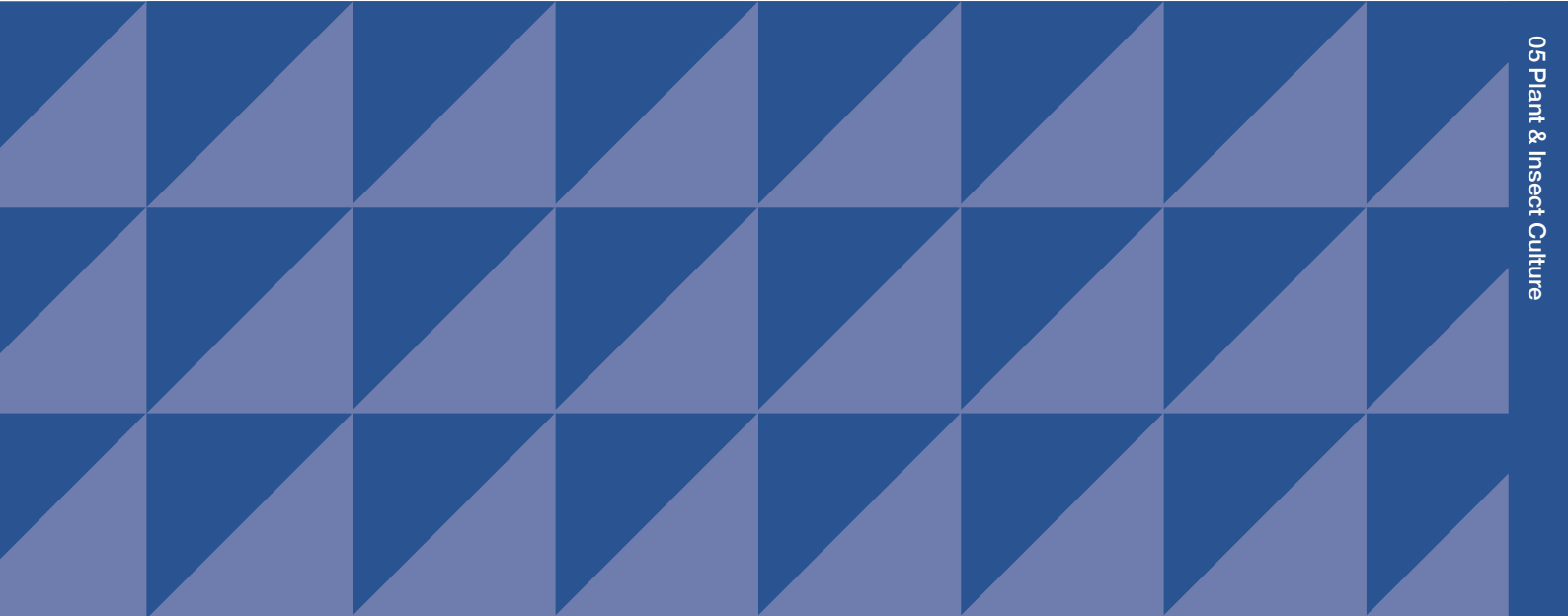

05 Plant & Insect Culture

Plant & Insect Culture

5-1. Plant Culture

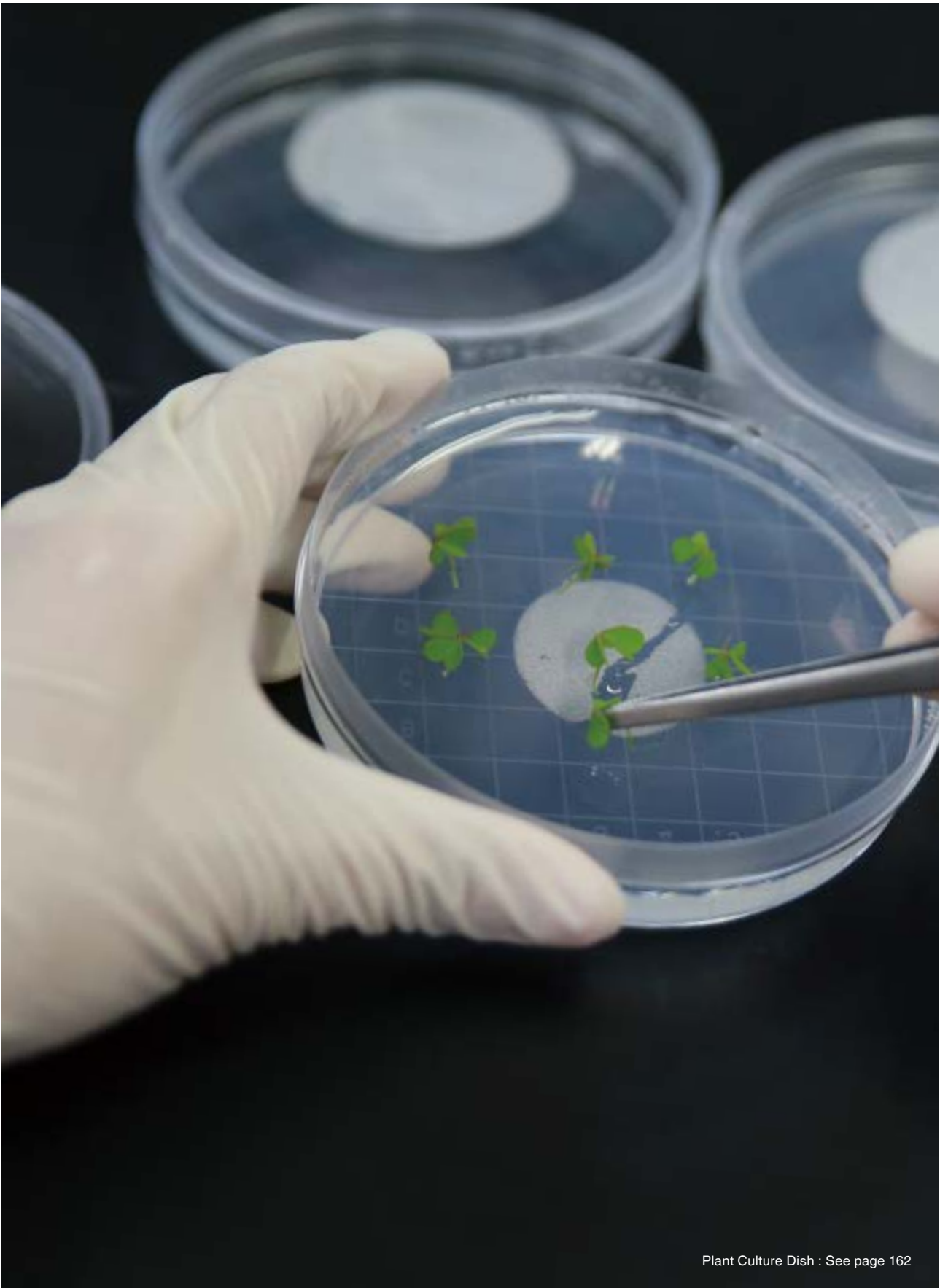

Plant Culture Dish : See page 162





Incu Tissue

Incu Tissues are ideal for plant tissue cultures. As the sprout grows, another Incu Tissue can be connected to the top as an optional frame.

- Embossing on the closing edge of cover and jar
- Optional frame (Cat. No. 310074) is only available for 310070 and 310071
- Cat. No. 310070 can be assembled with Insect Breeding Box (Cat. No. 310075, 310076, 310077)



Incu Tissue

Type	Cat. No.	Material	Style	External Dimensions w x l x h (mm)	Internal Dimensions w x l x h (mm)	Sterile	Packaging
	310070	PS	Square	72.00 x 72.00 x 100.00	65.40 x 65.40 x 98.20	+	4 / 120
	310071	PC	Square	72.00 x 72.00 x 100.00	65.40 x 65.40 x 98.20	-	4 / 120
	310072	PP	Square	72.00 x 72.00 x 100.00	65.40 x 65.40 x 98.20	-	4 / 120
	310074	PP	Frame	80.80 x 80.80 x 21.00	63.80 x 63.80 x 21.00	-	30 / 60

Plant & Insect Culture







Plant Culture Dish

Plant Culture Dishes are used for sprout culture. Pre-sterilized, flat dishes provide excellent culture results.

- Excellent air circulation design
- Excellent flatness
- Stable stacking
- Designed for reduced contamination
- Autoclavable (Cat. No. 310103, 310101)
- Gridded bottom (Cat. No. 310200)



Plant Culture Dish

Type	Cat. No.	Material	External Dimensions d x h (mm)	Internal Dimensions d x h (mm)	Autoclavable	Sterile	Packaging
	310103	PP	100.00 x 50.00	91.40 x 48.50	+	-	5 / 200
	310100	PS	100.00 x 40.00	91.30 x 38.20	-	+	5 / 200
	310101	PP	100.00 x 40.00	91.30 x 38.20	+	-	5 / 200
	310200	PS	100.00 x 20.00	94.60 x 18.60	-	+	10 / 200
	10090	PS	90.00 x 15.00	85.90 x 12.60	-	+	10 / 500
	10091	PS	90.00 x 20.00	86.20 x 17.70	-	+	10 / 200
	10100	PS	100.00 x 15.00	96.40 x 13.75	-	+	10 / 500

Plant Culture Bottle I

Plant Culture Bottles I are used for sprout or sapling culture.

- Stackable feature for space saving
- Designed for reduced contamination
- Screw cap



Plant Culture Bottle I

Type	Cat. No.	Material (Bottle / Cap)	Dimensions w x l x h (mm)	Total Vol. (ml)	Sterile	Packaging
	310500	PP / PP	100.00 x 100.00 x 110.00	500.00	-	1

Plant Culture Bottle II

Plant Culture Bottles II are used for culturing sapling or callus.

- Durable plastic bottle
- Designed for reduced contamination
- Screw cap
- Autoclavable



Plant Culture Bottle II

Type	Cat. No.	Material (Bottle / Cap)	Dimensions w x l x h (mm)	Total Vol. (ml)	Sterile	Packaging
	310501	PC / PP	115.00 x 115.00 x 140.00	500.00	-	1



Phytohealth

Phytohealth is useful for the culture of individual plantlet.

- Stackable feature for space saving
- Embossing on the closing edge of cover and the jar
- Phytohealth bodies and caps are packaged separately
- Autoclavable



Phytohealth

Type	Cat. No.	Material	External Dimensions d x h (mm)	Internal Dimensions-Body d x h (mm)	Internal Dimensions-Cap d x h (mm)	Sterile	Packaging
	310120	PP	120.00 x 80.00	103.00 x 78.60	101.00 x 10.20	-	400
	310121	PP	120.00 x 110.00	103.00 x 78.60	101.00 x 32.50	-	400

Plant & Insect Culture







AraHarvest

AraHarvest is a convenient system for culturing and harvesting seeds from individual sapling.

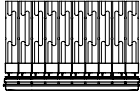
- AraHarvest set: Tube, Base, Basket, Top Tray, Bottom Tray (Cat. No. 310060)
- Aracon Tube (Cat. No. 310061)
- Aracon Base (Cat. No. 310062)
- Aracon Basket (Cat. No. 310063)
- Aracon Top Tray (Cat. No. 310064), space saving 50 hole tray
- Aracon Bottom Tray (Cat. No. 310065)



AraHarvest

Type	Cat. No.	Material	Tube	Base	Basket	Top Tray	Bottom Tray	Packaging
	310060	PS / PP	200 ea	200 ea	200 ea	4 ea	4 ea	
	310061	PS	100 ea					100
	310062	PS		100 ea				100
	310063	PP			100 ea			100
	310064	PP				4 ea		4
	310065	PP					4 ea	4

5-2. Insect Culture





Insect Breeding Dish & Jar

Insect Breeding Dishes and Jars are ideal containers for breeding and observing micro-insects. Ventilation hole on the cover enables excellent air circulation and easy humidity control.

- Easy to breed and observe micro-insects and their natural enemies
- Effective air circulation and humidity control
- Useful for room tests i.e., room breeding and drug screening
- Mesh located on the cap for ventilation and prevention of insect escape
- Stainless mesh type (Cat. No. 310202)
- External grip (Cat.No. 310050)
- Gridded bottom (Cat. No. 310201)



Insect Breeding Dish & Jar

Type	Cat. No.	Material	External Dimensions d x h (mm)	Internal Dimensions d x h (mm)	Ventilation Hole Size (mm)	Mesh Pore Size (µm)	Hole Position	Sterile	Packaging
	310050	PS	50.00 x 15.00	48.75 x 11.80	13.20	53.00	Cap	-	20 / 200
	310102	PS	100.00 x 40.00	91.35 x 38.50	40.00	53.00	Cap	-	5 / 200
	310122	PP	120.00 x 80.00	91.00 x 70.00	40.00	53.00	Cap	-	400
	310201	PS	100.00 x 20.00	94.62 x 18.60	40.00	53.00	Cap	-	10 / 200
	310202	PS	100.00 x 40.00	91.35 x 38.50	40.00	53.00	Cap	-	5 / 200

Plant & Insect Culture

Insect Breeding Box

Insect Breeding Boxes are ideal for breeding and observing micro-insects.





Ventilation hole on the cover enables excellent air circulation and easy humidity control.

- Easy to breed and observe micro-insects and natural enemies
- Effective air circulation and humidity control
- Useful for room tests i.e., room breeding and drug screening
- Mesh type: stainless or nylon (please inquire)
- All products can be assembled with Incu Tissue (Cat. No. 310070)
- Optimal Frame (Cat. No. 310074)



Insect Breeding Dish & Jar :
See page 165

Insect Breeding Box

Type	Cat. No.	Material	External Dimensions w x l x h (mm)	Internal Dimensions w x l x h (mm)	Ventilation Hole Size (mm)	Mesh Pore Size (µm)	Hole Position	Sterile	Packaging
	310075	PS	72.00 x 72.00 x 100.00	65.40 x 65.40 x 98.20	40.00	53.00	Cap	-	4 / 120
	310076	PS	72.00 x 72.00 x 100.00	65.40 x 65.40 x 98.20	40.00	53.00	Bottom	-	4 / 120
	310077	PS	72.00 x 72.00 x 100.00	65.40 x 65.40 x 98.20	40.00	53.00	Side & Bottom (3 Holes)	-	4 / 120
	310074	PP	80.80 x 80.80 x 21.00	63.80 x 63.80 x 21.00	-	-	-	-	30 / 60

Drosophila Vials

Drosophila Vials have excellent transparency and easy to observe the contents. Precision molded plastic Drosophila Vials are a safe and cost effective alternative to glass vials.

- For drosophila study and research
- 100 vials (10 x 10) per tray



Drosophila Vials

Type	Cat. No.	Material	External Dimensions d x h (mm)	Sterile	Packaging
	310301	PS	25.00 x 95.00	-	100 / 500

Drosophila Vial Plugs

Fit SPL Drosophila Vials and easy to use. SPL Drosophila Vial Plugs reduce evaporation.

- Fit SPL Drosophila Vials
- Reduces evaporation



Drosophila Vial Plugs

Type	Cat. No.	Material	External Dimensions d x h (mm)	Sterile	Packaging
	310300	Cotton	25.00 x 25.00	-	500

Clinical Labware

SPL Life Sciences provides labwares for storing clinical samples in different shapes and materials to be utilized for multiple purposes. All products are manufactured under strict quality protocols.

6-1. Clinical Labware 170

Specimen Cup & Bottle	170
Medical Container	171
Sample tube.....	171
Embedding Cassette	172
Super Mega Cassette	173
Serum Separating Tube.....	173
Medical Tube	174
Vacuum Needle Holder.....	175
Sample Cup	175
Transport Tube	176
Transport Bottle	176



Specimen Cup & Bottle : See page 170

Clinical Labware

6-1. Clinical Labware







Specimen Cup & Bottle

SPL Life Sciences provides high quality Specimen Cups & Bottles for medical sampling.

- Tight sealing screw cap
- External graduations with marking area
- Urine Cup: No Cap, pouring region (Cat. No. 400121)
- Female Urine Cup (Cat. No. 410200)
- Separate packaging of caps and bodies (Cat. No. 401120)
- Compatible with the pneumatic tube systems for hospitals (Cat. No. 410120)
- Suitable for an automation equipment (#400730: Hitachi / #400720 : Toshiba)



Specimen Cup & Bottle

Type	Cat. No.	Material (Tube / Cap)	Total Vol. (ml)	Sterile	Packaging
	400120	PP / PE	120.00	+	5 / 250
	401120	PP / PE	120.00	-	Cap: 250 / 500, Body: 10 / 500
	400121	PP	120.00	-	10 / 500
	BA410120	PP / PE	120.00	+	5 / 250
	410200	PP	200.00	+	20 / 160
	400050	PP / PE	50.00	+	1 / 100
	400060	PP / PE	60.00	+	5 / 100
	401060	PP / PE	60.00	-	100

Medical Container

SPL Medical Containers are useful for storing and handling of medical samples.

- Ideal sampling containers for sputum or stool examination
- Tight sealing screw cap
- External graduation
- Self-standing conical bottom
- Spoons are provided for easy sampling: stool container (Cat. No. 400500)
- Container rack (Cat. No. 410025)
- Excellent stackability (Cat. No. 400025, 400125)



Medical Container

Type	Cat. No.	Material (Tube / Cap)	Color	Total Vol. (ml)	Sterile	Packaging
	400025	PP / PE	Clear	25.00	+	100 / 500
	400125	PP / PE	Clear	25.00	-	100 / 500
	401125	PS / PE	Clear	125.00	-	300 / 300
	400500	PP / PE	Black	25.00	-	100 / 500
	400501	PP / PE	Black	25.00	-	100 / 500
	410025	PS	White	-	-	1 / 20

Sample Tube

SPL Sample Tubes are designed for storing various clinical samples. SPL Life Sciences provides durable, easy-to-use bottles to meet various demands of customers.

- Tight sealing screw cap
- External graduations
- Self-standing conical bottom



Sample Tube

Type	Cat. No.	Material (Tube / Cap)	Total Vol. (ml)	External Dimensions d x h (mm)	Sterile	Packaging
	50221	PP / PE	20.00	25.00 x 73.00	-	25 / 500

Clinical Labware

Embedding Cassette

SPL Embedding Cassettes are suitable for holding and identifying tissue sample.

- Disposable plastic tissue cassettes are made from acetal polymer
- Wider unobstructed writing surface sloped at 40° angle
- Bases and separate lids packaging
- Integral lid type (Cat. No. 400600, 40060B, 40060G, 40060P, 40060Y)



Embedding Cassette

Type	Cat. No.	Material	Color	Type of Packaging	Packaging
	400600	Acetal	White	Bulk	2,000
	40060B	Acetal	Blue	Bulk	2,000
	40060G	Acetal	Green	Bulk	2,000
	40060P	Acetal	Pink	Bulk	2,000
	40060Y	Acetal	Yellow	Bulk	2,000
	400610	Acetal	White	Bulk	2,000
	40061B	Acetal	Blue	Bulk	2,000
	40061G	Acetal	Green	Bulk	2,000
	40061P	Acetal	Pink	Bulk	2,000
	40061Y	Acetal	Yellow	Bulk	2,000

Super Mega Cassette

SPL Super Mega Cassettes are specially designed to hold large specimens during embedding processes.

- Disposable plastic tissue cassettes are made from acetal polymer
- Supplied with PET base



Super Mega Cassette

Type	Cat. No.	Color	Material (Cassette / Base)	External Dimensions w x l x h (mm)	Packaging
	400800	Gray	Acetal / PET	57.60 x 80.80 x 16.50	100

Serum Separating Tube

SPL Serum Separating Tubes are designed to facilitate separation of serum and blood cells.

- Suitable for separating serum and blood cells
- Suitable for collection and storage of clinical specimen

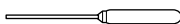

Serum Separating Tube

Type	Cat. No.	Material	Total Length (mm)	Total Vol. (mm)	Sterile	Packaging
	410514	PE	210.00	10.00	-	250 / 2,000

Clinical Labware







Medical Tube

SPL Medical Tubes are widely used and referenced in various laboratory protocols.

- Medical packaging
- Round type bottom & Internal graduations (Cat. No. 400510, 400511, 400520, 400521)
- Round type bottom (Cat. No. 400530, 400531)
- Conical bottom & Internal graduations (Cat. No. 401015)
- Caps are provided for tight sealing (Cat. No. 400530)



Medical Tube

Type	Cat. No.	Material (Tube / Cap)	Total Vol. (ml)	External Dimensions d x h (mm)	Sterile	Packaging
	400510	PS	5.00	12.00 x 75.00	-	250 / 2,000
	400511	PP	5.00	12.00 x 75.00	-	250 / 2,000
	400520	PS	14.00	17.00 x 95.40	-	25 / 2,000
	400521	PP	14.00	17.00 x 95.40	-	25 / 2,000
	400530	PS / PE	10.00	15.56 x 99.92	-	100 / 1,000
	400531	PS	10.00	15.56 x 99.92	-	100 / 1,000
	401015	PS	12.00	16.88 x 107.70	-	200 / 2,000

Vacuum Needle Holder

SPL Vacuum Needle Holders are designed for blood collection. The holders provide fixed retention of the needle and tube during blood collection.

- Suitable for Vacuum Blood Collection
- Non-slip handle
- Disposable



Vacuum Needle Holder

Type	Cat. No.	Material	Total Length (mm)	Sterile	Packaging
	BA400900	PP	47.50	-	250 / 1,000

Sample Cup

SPL Sample Cups are designed for clinical pathology testing of blood.

- Suitable for an automation equipment (#400730: Hitachi / #400720 : Toshiba)
- Useful for clinical pathology test
- Self standing conical bottom



Sample Cup

Type	Cat. No.	Material	Working Vol. (ml)	Packaging
	400720	PS	2.00	1,000 / 10,000
	400730	PS	3.00	1,000 / 6,000

Clinical Labware

Transport Tube

SPL Transport Tubes for safe transport of pathogenic organisms and clinical specimens; they are tightly sealed to prevent possible leakage.

- Non-pyrogenic
- Non-cytotoxic
- DNase / RNase-free

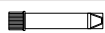

Transport Tube

Type	Cat. No.	Material (Tube / Cap)	Total Vol. (ml)	Sterile	Packaging
	BA50212	PP / PE	12.00	+	50 / 1,000



Transport Bottle

SPL Transport Bottles are specially designed for safe transport of pathogenic organisms and clinical specimens; they are tightly sealed to prevent possible leakage.

- For category A, UN2814 (Cat.No 401000)
- For category B, UN3373 (Cat.No 411000)
- 1,000 ml secondary container including absorbent, cushioning material, and labels
- Category A: An infectious substance which is transported in a form that, when exposure to it occurs, is capable of causing permanent disability, life-threatening or fatal disease in otherwise healthy humans or animals.
- Category B: An infectious substance which does not meet the criteria for inclusion in Category A.



Transport Tube

Type	Cat. No.	Color (Cap / Body)	Material (Cap / Body)	External Dimensions d x h x l (mm)	Internal Dimensions d x h (mm)	Total Vol. (ml)	Empty Weight (g)	Packaging
	401000	Red / Natural	PP / PP	164.00 x 164.00 x 168.00	132.00 x 155.00	1,000.00	260.00	1 / 10
	411000	Red / Natural	PP / PP	112.00 x 110.00 x 190.00	107.50 x 176.30	1,000.00	147.00	1 / 10

Appendix

- Product Raw Material Chemical Resistance Chart
- Alphabetical Index
- Numerical Index

Product Raw material Chemical Resistance Chart

Chemical	LDPE		HDPE		PP		PS		PET	
	RT	50-60°C	RT	50-60°C	RT	50-60°C	RT	50-60°C	RT	50-60°C
Acetaldehyde, pure	B	D	B	C	A	A	D	D	-	-
Acetic acid 5%	A	A	A	A	A	A	A	B	B	-
Acetic acid 50%	B	C	A	B	A	A	B	B	C	D
Acetone, pure	D	D	D	D	A	A	D	D	D	D
Acetonitrile, pure	A	A	A	A	A	B	D	D	-	-
Ammonium acetate, saturated	A	A	A	A	A	A	A	A	-	-
Ammonium Hydroxide, 5%	A	A	A	A	A	A	A	C	C	D
Ammonium Hydroxide, 30%	A	B	A	A	A	B	B	C	D	D
Butyric Acid, pure	D	D	C	D	B	B	D	D	D	D
Chloroform, pure	C	D	C	D	B	C	D	D	-	-
Chromic acid, 50%	A	A	A	A	B	C	C	D	-	-
Cyclohexane, pure	C	D	C	D	B	C	D	D	-	-
Dimethylsulfoxide, pure	A	A	A	A	A	A	A	B	D	D
Ether, pure	D	D	C	D	D	D	D	D	A	-
Ethyl alcohol, 40%	A	B	A	A	A	A	A	B	B	-
Ethyl alcohol, pure	A	B	A	A	A	A	A	B	B	-
Ethyl glycol, pure	A	A	A	A	A	A	A	A	A	-
Formaldehyde, 10%	A	A	A	A	A	A	B	B	-	-
Formaldehyde, 40%	A	B	A	B	A	A	B	B	-	-
Formic Acid, 3%	A	B	A	A	A	A	A	A	-	-
Formic Acid, 50%	B	B	A	A	A	B	B	C	-	-
Glutaraldehyde, pure	A	B	A	A	A	A	A	C	-	-
Glutaraldehyde Disinfectant	A	B	A	A	A	A	A	C	-	-
Glycerine, pure	A	A	A	A	A	A	A	A	A	-
Glycerol, pure	A	A	A	A	A	A	A	A	A	-
Hexane	D	D	D	D	A	C	D	D	-	-
Hydrochloric acid, 5%	A	A	A	A	A	A	A	A	A	-
Hydrochloric acid, 35%	A	A	A	A	A	B	A	A	C	D
Hydrogen peroxide, 3%	A	A	A	A	A	B	A	B	A	-
Hydrogen peroxide, 30%	A	B	A	A	A	C	A	B	A	-
Isobutyl alcohol, pure	A	A	A	A	A	A	B	B	-	-
Isopropanol, pure	A	A	A	A	A	A	A	B	-	-
Methyl Alcohol, pure	A	B	A	A	A	A	B	C	B	-
Methyl Ethyl ketone, pure	D	D	D	D	A	B	D	D	B	-
Nitric acid 10%	A	A	A	A	A	A	B	D	B	-
Nitric acid 70%	C	D	C	D	C	C	D	D	D	D
Phenol, liquid	D	D	D	D	D	D	D	D	D	D
Phosphoric, acid, 5%	A	A	A	A	A	A	A	A	-	-
Phosphoric, acid, 85%	A	D	A	A	A	B	A	B	-	-
Picric acid, pure	D	D	D	D	D	D	B	C	-	-
Potassium hydroxide 1%	A	A	C	C	A	A	A	B	-	-
Potassium hydroxide, concentrated	A	A	A	A	A	A	B	B	-	-
Sulfuric acid, 6%	A	A	A	A	A	A	A	A	A	-
Sulfuric acid, 98%	B	B	C	D	A	C	C	C	D	D
Trichloroacetic acids	C	D	C	D	B	C	C	D	-	-

A - Resistance, B - Limited resistance, C - Some effect after 7 days of constant exposure, D - Immediate damage

- The above chemical resistance chart is for general guidelines only.
- Since multiple factors may affect the chemical resistance of a given product, you should test under your own conditions.

Alphabetical Index

1	
1.5 ml Strip Tube	127
25 ml Conical Tube	119
25 ml Tube Adapter	151
25 ml Tube Storage Box	135
250 ml conical tube	126
2well Conical Tube Rack	131
384 HT Plate	82
5 ml Screw Tube	120
5 ml Snap Tube	121
5 ml Snap Tube Adapter	151
5 ml Tube Rack	132
5 ml Tube Storage Box	135
96well Hanging Drop Plate	52
A	
Antibiotic Disc	107
AraHarvest	164
Aspiration Pipette	112
Autoclaving Jar	150
B	
B & W Immunoplate Strip	81
Bacteria Culture Tube	103
Biohazard Bag	155
Bioreactor	29
Biotainer	144
Black & White Immunoplate	80
Black & White Plate 96well	24
Black Plate	39
Blender Bag	115
Blood Separation Tube	89
Bottle Top Filter	92
Bottle Top Filter Unit	93
C	
Cell Culture Dish	21
Cell Culture Flask	19
Cell Culture Module Plate	29
Cell Culture Plate	22
Cell Culture Plate 4well	65
Cell Culture Slide Hybridwell™	46
Cell Culture Slide I	42
Cell Culture Slide II	44
Cell Culture Square Bottle	28
Cell Floater	48
Cell Lifter	74
Cell Scraper	74
Cell Strainer	72
Cloning Cylinder	75
Co Culture Slide	45

Co-culture Dish (JLK)	55
Collagen Type I Coated Ware	32
Collagen Type IV Coated Ware	35
Confocal Dish & Plate	46
Conical Tube	116
Conical Tube Rack I	130
Conical Tube Rack II	130
Conical Tube Storage Box	134
Coverslip	41
Cryo Box	68
Cryo Tissue Container	67
Cryovial	66
Cryovial Rack	69
Cuvette	90
D	
Deep Well Plate	146
Deep Well Reservoir	148
Dialysis Chamber	88
Disposable Tweezers	154
Dropper	114
Drosophila Vial Plugs	167
Drosophila Vials	167
E	
Embedding Cassette	172
Erlenmeyer Flask	27, 104
F	
Fibronectin Coated Ware	36
Filter Tube	86
G	
Gel Extractor	89
Glove (Safe Guard)	153
Grid Sticker	107
I	
Immunoplate	79
Immunoplate Strip	79
Immunoplate Strip Single Well	80
Immunotube	83
Incu Tissue	161
Insect Breeding Box	166
Insect Breeding Dish & Jar	165
IVF Dish	65
L	
Label Protection Tape	152
Laminin Coated Ware	34
Loop & Needle	106

M	
Matrix™ Coated Ware	37
Media Bottle	140
Medical Container	171
Medical Tube	174
Micro Vial	124
Microcentrifuge Tube	128
Micropipette Tip	112
Microscopy Coverslip	41
Microtube Rack	133
Miniwell Tray	24 , 82
MOUZIP®	150
Multi C-Strainer	73
Multi Insert Dish	52
N	
Narrow-Mouth Bottle (Amber)	142
Narrow-Mouth Bottle (HDPE)	141
Narrow-Mouth Bottle (PP)	143
O	
Omni Box	150
P	
Partition Petri Dish	101
PCR Plate	85
PCR Tube	84
PCR Tube Rack	133
Petri Dish	100
Phytohealth	163
Plant Culture Bottle I	163
Plant Culture Bottle II	163
Plant Culture Dish	162
Poly-D-Lysine Coated Ware	33
Port Cap	145
Protein Safe	127
Q	
Q-suction 8-Tip	114
R	
Reinforced Tube	125
Reservoirs	148
RODAC Plate	102
Roller Bottle	26
S	
Sample Cup	175
Sample tube	171
Sealing Mat	147
Septum Tube	122
Serological Pipette	110
Serum Separating Tube	173
Silicone Tubing	156
Snap Tube	
Snap Tube	118
Snap Tube Rack	131
Specimen Cup & Bottle	170
Spheroid Dish	50
Spheroid Forming Gel	51
Spheroid Forming Unit	50
Spin Column	93
SPL Lid	97
SPL SEAL™	96
SPL SEAL™ Aluminum Tape	97
SPL SEAL™ Pressure-sensitive tape	96
SPLFlow™	70
SPLInsert™ Hanging	56
SPLInsert™ Standing	58
SPLPermea™ Bag	60
SPLPermea™ Dish	60
SPLPermea™ Rack	61
SPLPro-Crystal™ Coverslip	95
SPLPro-Crystal™ Plate	94
SPLScar™ Block	63
SPLScar™ Scratcher	62
Spreaders	106
Square Dish	25, 102
Stacker Microtube Rack	132
Standing Microtube Rack	133
Storage Bottle	144
Storage Box	134
Storage Plate 96well	149
Strainer Tube	75
Super Mega Cassette	173
T	
Test Tube	123
Transport Bottle	176
Transport Tube	176
Tray Plate	25, 103
U	
UVMax™	91
V	
Vacuum Filter Tube	87
Vacuum Needle Holder	175
W	
Water Sample Bottle	154
White Plate	40
Wide-Mouth Bottle (Amber)	138
Wide-Mouth Bottle (HDPE)	137
Wide-Mouth Bottle (PP)	139

Numerical Index

1

10035	Petri Dish.....	100	201904	SPLScar™ Block.....	63
100350	Confocal Dish & Plate	46	201906	SPLScar™ Scratcher	62
100351	Confocal Dish & Plate	46	201907	SPLScar™ Scratcher	62
10050	Petri Dish.....	100	201914	SPLScar™ Block.....	63
10060	Petri Dish.....	100	201916	SPLScar™ Block.....	63
10061	RODAC Plate	102	201924	SPLScar™ Scratcher	62
10063	RODAC Plate	102	201925	SPLScar™ Scratcher	62
10090	Petri Dish.....	100 , 162	201930	SPLScar™ Block.....	63
10091	Petri Dish.....	100 , 162	201934	SPLScar™ Block.....	63
10092	Partition Petri Dish.....	101	201935	SPLScar™ Block.....	63
10093	Petri Dish.....	100	201936	SPLScar™ Block.....	63
10094	Partition Petri Dish.....	101	201937	SPLScar™ Block.....	63
10095	Petri Dish.....	100	201938	SPLScar™ Block.....	63
10096	Petri Dish.....	100	201939	SPLScar™ Block.....	63
10097	Partition Petri Dish.....	101	202501	SPLFlow™	70
10100	Petri Dish.....	100 , 162	202502	SPLFlow™	70
10101	Petri Dish.....	100	20260	IVF Dish	65
10125	Square Dish.....	25	20261	IVF Dish	65
101350	Confocal Dish & Plate	46	20262	IVF Dish	65
10150	Petri Dish.....	100	20263	IVF Dish	65
10151	Petri Dish.....	100	209200	Co-culture Dish (JLK)	55
10192	Partition Petri Dish.....	101	209260	Co-culture Dish (JLK)	55
102350	Confocal Dish & Plate	46	21002	Reservoirs	148
10245	Square Dish.....	102	21008	Reservoirs	148
10292	Partition Petri Dish.....	101	21012	Reservoirs	148
103350	Confocal Dish & Plate	46	21035	Collagen Type I Coated Ware	32
104350	Confocal Dish & Plate	46	210350	Confocal Dish & Plate	46
11035	Cell Culture Dish	21	21060	Collagen Type I Coated Ware.....	32
110350	Spheroid Dish.....	50	21100	Collagen Type I Coated Ware.....	32
11060	Cell Culture Dish	21	21102	Reservoirs	148
11090	Cell Culture Dish	21	211350	Confocal Dish & Plate	46
11125	Square Dish.....	102	212350	Confocal Dish & Plate	46
111350	Spheroid Dish.....	50	213350	Confocal Dish & Plate	46
11150	Cell Culture Dish	21	214350	Confocal Dish & Plate	46
11151	Cell Culture Dish	21	22001	Reservoirs	148
11245	Square Dish.....	102	22050	Reservoirs	148
			22100	Poly-D-Lysine Coated Ware.....	33
			22150	Poly-D-Lysine Coated Ware.....	33
			23001	Reservoirs	148
			230106	Confocal Dish & Plate	46
			230206	Confocal Dish & Plate	46
			23035	Laminin Coated Ware.....	34
			23050	Reservoirs	148
			23100	Laminin Coated Ware.....	34
			24100	Collagen Type IV Coated Ware.....	35
			25035	Fibronectin Coated Ware	36
			25100	Fibronectin Coated Ware	36
			25150	Fibronectin Coated Ware	36
			26035	Cell Floater	48
			26060	Cell Floater	48
			26100	Cell Floater	48
			27035	Matrix™ Coated Ware.....	37
			27060	Matrix™ Coated Ware.....	37
			27100	Matrix™ Coated Ware.....	37
			27150	Matrix™ Coated Ware.....	37
			3		
			30001	Tray Plate	25
			30004	Cell Culture Plate 4well	65
			30006	Cell Culture Plate	22

30012	Cell Culture Plate	22	310120	Phytohealth	163
30024	Cell Culture Plate	22	310121	Phytohealth	163
30048	Cell Culture Plate	22	310122	Insect Breeding Dish & Jar	165
30060	Miniwell Tray	24 , 82	310123	Autoclaving Jar	150
30072	Miniwell Tray	24 , 82	310200	Plant Culture Dish	162
300906	Cell Culture Module Plate.....	29	310201	Insect Breeding Dish & Jar	165
300924	Cell Culture Module Plate.....	29	310202	Insect Breeding Dish & Jar	165
30096	Cell Culture Plate	22	31024	Cell Culture Plate	22
30101	Cell Culture Slide I.....	42	310300	Drosophila Vial Plugs	167
30102	Cell Culture Slide I.....	42	310301	Drosophila Vials	167
30104	Cell Culture Slide I.....	42	31048	Cell Culture Plate	22
30106	Confocal Dish & Plate	46	310500	Plant Culture Bottle I	163
30108	Cell Culture Slide I.....	42	310501	Plant Culture Bottle II.....	163
30111	Cell Culture Slide I.....	42	31060	Miniwell Tray	24 , 82
30112	Cell Culture Slide I.....	42	31072	Miniwell Tray	24 , 82
30114	Cell Culture Slide I.....	42	31096	Cell Culture Plate	22
30118	Cell Culture Slide I.....	42	31101	Cell Culture Slide II.....	44
30121	Cell Culture Slide I.....	42	31102	Cell Culture Slide II.....	44
30122	Cell Culture Slide I.....	42	31104	Cell Culture Slide II.....	44
30124	Cell Culture Slide I.....	42	31108	Cell Culture Slide II.....	44
30128	Cell Culture Slide I.....	42	31111	Cell Culture Slide II.....	44
30196	Black & White Plate 96well.....	24	31112	Cell Culture Slide II.....	44
30206	Confocal Dish & Plate	46	31114	Cell Culture Slide II.....	44
30296	Black & White Plate 96well.....	24	31118	Cell Culture Slide II.....	44
30308	Poly-D-Lysine Coated Ware.....	33	31121	Cell Culture Slide II.....	44
30396	Black & White Plate 96well.....	24	31122	Cell Culture Slide II.....	44
30401	Cell Culture Slide I.....	42	31124	Cell Culture Slide II.....	44
30402	Cell Culture Slide I.....	42	31128	Cell Culture Slide II.....	44
30404	Cell Culture Slide I.....	42	31196	Black & White Immunoplate	80
30408	Cell Culture Slide I.....	42	31296	Black & White Immunoplate	80
30496	Black & White Plate 96well.....	24	31384	384 HT Plate	82
30501	Cell Culture Slide I.....	42	31396	Black & White Immunoplate	80
30502	Cell Culture Slide I.....	42	31401	Cell Culture Slide II.....	44
30504	Cell Culture Slide I.....	42	31402	Cell Culture Slide II.....	44
30508	Cell Culture Slide I.....	42	31404	Cell Culture Slide II.....	44
30608	Collagen Type IV Coated Ware.....	35	31408	Cell Culture Slide II.....	44
30704	Fibronectin Coated Ware	36	31496	Black & White Immunoplate	80
30708	Fibronectin Coated Ware	36	31501	Cell Culture Slide II.....	44
31001	Tray Plate.....	103	31502	Cell Culture Slide II.....	44
310050	Insect Breeding Dish & Jar.....	165	31504	Cell Culture Slide II.....	44
31006	Cell Culture Plate	22	31508	Cell Culture Slide II.....	44
310060	AraHarvest	164	31596	B & W Immunoplate Strip	81
310061	AraHarvest	164	31696	B & W Immunoplate Strip	81
310062	AraHarvest	164	31796	B & W Immunoplate Strip	81
310063	AraHarvest	164	31896	B & W Immunoplate Strip	81
310064	AraHarvest	164	32004	Cell Culture Plate 4well	65
310065	AraHarvest	164	32006	Cell Culture Plate	22
310070	Incu Tissue	161	32012	Cell Culture Plate	22
310071	Incu Tissue	161	32024	Cell Culture Plate	22
310072	Incu Tissue	161	32048	Cell Culture Plate	22
310074	Incu Tissue	161 , 166	32096	Cell Culture Plate	22
310075	Insect Breeding Box	166	32296	Immunoplate.....	79
310076	Insect Breeding Box	166	32384	384 HT Plate	82
310077	Insect Breeding Box	166	32396	Immunoplate.....	79
310100	Plant Culture Dish	162	32402	Co Culture Slide	45
310101	Plant Culture Dish	162	32404	Co Culture Slide	45
310102	Insect Breeding Dish & Jar.....	165	32496	Immunoplate.....	79
310103	Plant Culture Dish	162	32502	Co Culture Slide	45
31012	Cell Culture Plate	22	32504	Co Culture Slide	45

32596	Immunoplate.....	79	35324	SPLInsert™ Standing.....	58
32696	Immunoplate.....	79	35384	384 HT Plate	82
32796	Immunoplate.....	79	35406	SPLInsert™ Standing.....	58
330384	UVMax™.....	91	35424	SPLInsert™ Standing.....	58
33096	UVMax™.....	91	35506	SPLInsert™ Standing.....	58
33101	Cell Culture Slide Hybridwell™.....	46	35524	SPLInsert™ Standing.....	58
331096	96well Hanging Drop Plate.....	52	36006	SPLInsert™ Hanging.....	56
331196	96well Hanging Drop Plate.....	52	36012	SPLInsert™ Hanging.....	56
331296	96well Hanging Drop Plate.....	52	36024	SPLInsert™ Hanging.....	56
33196	Black Plate	39	36106	SPLInsert™ Hanging.....	56
33201	Cell Culture Slide Hybridwell™.....	46	36112	SPLInsert™ Hanging.....	56
33212	Black Plate	39	36124	SPLInsert™ Hanging.....	56
33224	Black Plate	39	36196	Cell Culture Plate	22
332384	Black Plate	39	36206	SPLInsert™ Hanging.....	56
33296	Black Plate	39	36212	SPLInsert™ Hanging.....	56
33301	Cell Culture Slide Hybridwell™.....	46	36224	SPLInsert™ Hanging.....	56
33312	Black Plate	39	36296	Cell Culture Plate	22
33324	Black Plate	39	36306	SPLInsert™ Standing.....	58
333384	Black Plate	39	36324	SPLInsert™ Standing.....	58
33384	384 HT Plate	82	36384	384 HT Plate	82
33396	Black Plate	39	36396	Storage Plate 96well	149
334624	SPLPro-Crystal™ Plate.....	94	36406	SPLInsert™ Standing.....	58
334696	SPLPro-Crystal™ Plate.....	94	36424	SPLInsert™ Standing.....	58
334724	SPLPro-Crystal™ Plate.....	94	36506	SPLInsert™ Standing.....	58
33496	White Plate	40	36524	SPLInsert™ Standing.....	58
335384	White Plate	40	37006	SPLInsert™ Hanging.....	56
33596	White Plate	40	37012	SPLInsert™ Hanging.....	56
336196	Storage Plate 96well	149	37024	SPLInsert™ Hanging.....	56
336384	White Plate	40	37106	SPLInsert™ Hanging.....	56
336396	Storage Plate 96well	149	37112	SPLInsert™ Hanging.....	56
33696	White Plate.....	40	37124	SPLInsert™ Hanging.....	56
34002	Deep Well Reservoir	148	37206	SPLInsert™ Hanging.....	56
34008	Deep Well Plate.....	146	37212	SPLInsert™ Hanging.....	56
34096	Cell Culture Plate	22	37224	SPLInsert™ Hanging.....	56
34102	Deep Well Reservoir	148	37306	SPLInsert™ Standing.....	58
34108	Deep Well Plate.....	146	37324	SPLInsert™ Standing.....	58
34196	Cell Culture Plate	22	37384	Cell Culture Plate	22
34296	Cell Culture Plate	22	37406	SPLInsert™ Standing.....	58
34384	384 HT Plate	82	37424	SPLInsert™ Standing.....	58
34396	Storage Plate 96well	149	37506	SPLInsert™ Standing.....	58
34496	Deep Well Plate.....	146	37524	SPLInsert™ Standing.....	58
34596	Deep Well Plate.....	146	38096	Immunoplate Strip	79
34696	Deep Well Plate.....	146	38196	Immunoplate Strip	79
34796	Deep Well Plate.....	146	38296	Immunoplate Strip Single Well	80
34896	Cell Floater.....	48	38384	Cell Culture Plate	22
35001	SPL Lid.....	97	38396	Immunoplate Strip Single Well	80
35006	SPLInsert™ Hanging.....	56	38496	Immunoplate Strip	79
35012	SPLInsert™ Hanging.....	56	38596	Immunoplate Strip	79
35024	SPLInsert™ Hanging.....	56	38696	Immunoplate Strip Single Well	80
35096	SPL Lid.....	97	38796	Immunoplate Strip Single Well	80
35101	SPL Lid.....	97	39006	Collagen Type I Coated Ware	32
35106	SPLInsert™ Hanging.....	56	39012	Collagen Type I Coated Ware	32
35112	SPLInsert™ Hanging.....	56	39024	Collagen Type I Coated Ware	32
35124	SPLInsert™ Hanging.....	56	39048	Collagen Type I Coated Ware	32
35196	SPL Lid.....	97	39096	Collagen Type I Coated Ware	32
35206	SPLInsert™ Hanging.....	56	39206	Poly-D-Lysine Coated Ware	33
35212	SPLInsert™ Hanging.....	56	39212	Poly-D-Lysine Coated Ware	33
35224	SPLInsert™ Hanging.....	56	39224	Poly-D-Lysine Coated Ware	33
35306	SPLInsert™ Standing.....	58	39296	Poly-D-Lysine Coated Ware	33

39312	Laminin Coated Ware.....	34	410511	Gel Extractor	89
39348	Laminin Coated Ware.....	34	410514	Serum Separating Tube	173
39396	Laminin Coated Ware.....	34	411000	Transport Bottle.....	176
39524	Fibronectin Coated Ware	36	42105	Test Tube	123
39596	Fibronectin Coated Ware	36	42114	Test Tube	123
39606	Matrix™ Coated Ware.....	37	43005	Immunotube	83
39612	Matrix™ Coated Ware.....	37	43012	Cryovial	66
39624	Matrix™ Coated Ware.....	37	43014	Cryo Tissue Container.....	67
39706	Cell Floater	48	43015	Immunotube	83
39724	Cell Floater	48	43021	Cryovial	66
39796	Cell Floater	48	43022	Cryovial	66
4			43023	Cryovial	66
400025	Medical Container	171	43032	Cryovial	66
40005	Test Tube	123	43055	Immunotube	83
400050	Specimen Cup & Bottle	170	43111	Cryovial	66
400060	Specimen Cup & Bottle	170	43112	Cryovial	66
400120	Specimen Cup & Bottle	170	43113	Cryovial	66
400121	Specimen Cup & Bottle	170	44022	Cryovial	66
400125	Medical Container	171	44112	Cryovial	66
40014	Test Tube	123	45002	Micro Vial.....	124
400500	Medical Container	171	45015	Micro Vial.....	124
400501	Medical Container	171	45115	Micro Vial.....	124
400510	Medical Tube.....	174	45402	Micro Vial.....	124
400511	Medical Tube.....	174	46015	Cuvette	90
400520	Medical Tube.....	174	46045	Cuvette	90
400521	Medical Tube.....	174	46115	Cuvette	90
400530	Medical Tube.....	174	46145	Cuvette	90
400531	Medical Tube.....	174	47020	Reinforced Tube.....	125
400600	Embedding Cassette.....	172	47120	Reinforced Tube.....	125
40060B	Embedding Cassette.....	172	47220	Reinforced Tube.....	125
40060G	Embedding Cassette.....	172	47320	Reinforced Tube.....	125
40060P	Embedding Cassette.....	172	5		
40060Y	Embedding Cassette.....	172	50005	5 ml Snap Tube.....	121
400610	Embedding Cassette.....	172	50015	Conical Tube	116
40061B	Embedding Cassette.....	172	50025	25 ml Conical Tube	119
40061G	Embedding Cassette.....	172	50040	Conical Tube	116
40061P	Embedding Cassette.....	172	50050	Conical Tube	116
40061Y	Embedding Cassette.....	172	50105	5 ml Snap Tube.....	121
400720	Sample Cup.....	175	50115	Conical Tube	116
400730	Sample Cup.....	175	50150	Conical Tube	116
400800	Super Mega Cassette.....	173	50215	Snap Tube.....	118
401000	Transport Bottle.....	176	50221	Sample tube	171
401015	Medical Tube.....	174	50225	25 ml Conical Tube	119
40105	Test Tube	123	50250	Conical Tube	116
401060	Specimen Cup & Bottle	170	50315	Snap Tube.....	118
401120	Specimen Cup & Bottle	170	50351	Bioreactor.....	29
401125	Medical Container	171	50415	Snap Tube.....	118
40114	Test Tube	123	50450	Snap Tube.....	118
40205	Test Tube	123	50515	Conical Tube	116
40405	Strainer Tube.....	75	50550	Snap Tube.....	118
410011	Water Sample Bottle	154	50650	Snap Tube.....	118
410012	Water Sample Bottle	154	50715	Septum Tube.....	122
410014	Water Sample Bottle	154	50750	Septum Tube.....	122
410025	Medical Container	171	508150	Bottle Top Filter.....	92
41005	Test Tube	123	508151	Bottle Top Filter.....	92
41014	Test Tube	123	50850	Vacuum Filter Tube	87
410200	Female Urine Cup	170	508500	Bottle Top Filter.....	92
410501	Dropper	114	508501	Bottle Top Filter.....	92
410502	Dropper	114	508502	Bottle Top Filter Unit.....	93

508503	Bottle Top Filter Unit.....	93	54005	5 ml Snap Tube.....	121
50851	Vacuum Filter Tube.....	87	54015	Conical Tube.....	116
50915	Blood Separation Tube.....	89	54050	Conical Tube.....	116
50916	Blood Separation Tube.....	89	54105	5 ml Snap Tube.....	121
50950	Blood Separation Tube.....	89	54115	Conical Tube.....	116
50951	Blood Separation Tube.....	89	54150	Conical Tube.....	116
51000	Cell Culture Square Bottle.....	28	55005	5 ml Snap Tube.....	121
51001	Cell Culture Square Bottle.....	28	550250	Storage Bottle.....	144
51005	5 ml Screw Tube.....	120	550500	Storage Bottle.....	144
51015	Conical Tube.....	116	55085	Roller Bottle.....	26
51105	5 ml Screw Tube.....	120	551000	Storage Bottle.....	144
51115	Conical Tube.....	116	55105	5 ml Snap Tube.....	121
51125	Cell Culture Square Bottle.....	28	55185	Roller Bottle.....	26
51126	Cell Culture Square Bottle.....	28	55285	Roller Bottle.....	26
51150	Conical Tube.....	116	55385	Roller Bottle.....	26
51250	Cell Culture Square Bottle.....	28	558250	250 ml conical tube.....	126
51251	Cell Culture Square Bottle.....	28	56000	Media Bottle.....	140
51315	Bioreactor.....	29	56005	5 ml Screw Tube.....	120
51500	Cell Culture Square Bottle.....	28	56060	Media Bottle.....	140
51501	Cell Culture Square Bottle.....	28	56061	Media Bottle.....	140
516001	Narrow-Mouth Bottle (HDPE).....	141	56105	5 ml Screw Tube.....	120
516002	Narrow-Mouth Bottle (HDPE).....	141	56125	Media Bottle.....	140
516003	Narrow-Mouth Bottle (HDPE).....	141	562000	Biotainer.....	144
516004	Narrow-Mouth Bottle (HDPE).....	141	56250	Media Bottle.....	140
516005	Narrow-Mouth Bottle (HDPE).....	141	56500	Media Bottle.....	140
516006	Narrow-Mouth Bottle (HDPE).....	141	565000	Biotainer.....	144
516007	Narrow-Mouth Bottle (HDPE).....	141	57000	Wide-Mouth Bottle (Amber).....	138
516008	Narrow-Mouth Bottle (HDPE).....	141	57020	Wide-Mouth Bottle (Amber).....	138
516009	Narrow-Mouth Bottle (HDPE).....	141	57030	Wide-Mouth Bottle (Amber).....	138
516010	Narrow-Mouth Bottle (Amber).....	142	57060	Wide-Mouth Bottle (Amber).....	138
516011	Narrow-Mouth Bottle (Amber).....	142	57125	Wide-Mouth Bottle (Amber).....	138
516012	Narrow-Mouth Bottle (Amber).....	142	57250	Wide-Mouth Bottle (Amber).....	138
516013	Narrow-Mouth Bottle (Amber).....	142	57500	Wide-Mouth Bottle (Amber).....	138
516014	Narrow-Mouth Bottle (Amber).....	142	58000	Wide-Mouth Bottle (PP).....	139
516015	Narrow-Mouth Bottle (Amber).....	142	58005	Wide-Mouth Bottle (PP).....	139
516016	Narrow-Mouth Bottle (Amber).....	142	58020	Wide-Mouth Bottle (PP).....	139
516017	Narrow-Mouth Bottle (Amber).....	142	58030	Wide-Mouth Bottle (PP).....	139
516018	Narrow-Mouth Bottle (Amber).....	142	58031	Wide-Mouth Bottle (PP).....	139
516019	Narrow-Mouth Bottle (PP).....	143	58060	Wide-Mouth Bottle (PP).....	139
516020	Narrow-Mouth Bottle (PP).....	143	58125	Wide-Mouth Bottle (PP).....	139
516021	Narrow-Mouth Bottle (PP).....	143	58250	Wide-Mouth Bottle (PP).....	139
516022	Narrow-Mouth Bottle (PP).....	143	58500	Wide-Mouth Bottle (PP).....	139
516023	Narrow-Mouth Bottle (PP).....	143	59000	Wide-Mouth Bottle (HDPE).....	137
516024	Narrow-Mouth Bottle (PP).....	143	59015	Bacteria Culture Tube.....	103
516025	Narrow-Mouth Bottle (PP).....	143	59020	Wide-Mouth Bottle (HDPE).....	137
516026	Narrow-Mouth Bottle (PP).....	143	59030	Wide-Mouth Bottle (HDPE).....	137
516027	Narrow-Mouth Bottle (PP).....	143	59031	Wide-Mouth Bottle (HDPE).....	137
516028	Narrow-Mouth Bottle (PP).....	143	59050	Bacteria Culture Tube.....	103
52005	5 ml Snap Tube Adapter.....	151	59060	Wide-Mouth Bottle (HDPE).....	137
52015	Conical Tube Rack I.....	130	59125	Wide-Mouth Bottle (HDPE).....	137
52025	25 ml Tube Adapter.....	151	59250	Wide-Mouth Bottle (HDPE).....	137
52050	Conical Tube Rack I.....	130	59500	Wide-Mouth Bottle (HDPE).....	137
52115	Conical Tube Rack II.....	130	6		
52150	Conical Tube Rack II.....	130	60001	PCR Tube.....	84
52202	2well Conical Tube Rack.....	131	60008	PCR Tube.....	84
53005	5 ml Screw Tube.....	120	60011	PCR Tube.....	84
53015	Snap Tube Rack.....	131	60015	Microcentrifuge Tube.....	128
53050	Snap Tube Rack.....	131	60017	Microcentrifuge Tube.....	128
53105	5 ml Screw Tube.....	120	60018	PCR Tube.....	84

60028	PCR Tube.....	84	73175	Cell Culture Flask.....	19
60048	PCR Tube.....	84	73250	Erlenmeyer Flask.....	27, 104
60096	PCR Plate.....	85	73500	Erlenmeyer Flask.....	27, 104
60115	Microcentrifuge Tube.....	128	74000	Erlenmeyer Flask.....	27, 104
60117	Microcentrifuge Tube.....	128	74002	Erlenmeyer Flask.....	27, 104
60396	PCR Plate.....	85	74003	Erlenmeyer Flask.....	27, 104
60615	1.5 ml Strip Tube.....	127	74175	Cell Culture Flask.....	19
60715	1.5 ml Strip Tube.....	127	74250	Erlenmeyer Flask.....	27, 104
61012	5 ml Tube Rack.....	132	74500	Erlenmeyer Flask.....	27, 104
61015	Microcentrifuge Tube.....	128	75000	Erlenmeyer Flask.....	104
61017	Microcentrifuge Tube.....	128	75002	Erlenmeyer Flask.....	104
61020	Microcentrifuge Tube.....	128	75003	Erlenmeyer Flask.....	104
61024	Standing Microtube Rack.....	133	75025	Collagen Type I Coated Ware.....	32
61048	Stacker Microtube Rack.....	132	75075	Collagen Type I Coated Ware.....	32
61050	Cryovial Rack.....	69	75125	Collagen Type I Coated Ware.....	32
61080	Microtube Rack.....	133	75250	Erlenmeyer Flask.....	104
61120	Microcentrifuge Tube.....	128	75500	Erlenmeyer Flask.....	104
62015	Microcentrifuge Tube.....	128	76000	Erlenmeyer Flask.....	104
62017	Microcentrifuge Tube.....	128	76002	Erlenmeyer Flask.....	104
64015	Microcentrifuge Tube.....	128	76003	Erlenmeyer Flask.....	104
64020	Microcentrifuge Tube.....	128	76075	Poly-D-Lysine Coated Ware.....	33
65015	Protein Safe.....	127	76250	Erlenmeyer Flask.....	104
65020	Protein Safe.....	127	76500	Erlenmeyer Flask.....	104
65105	Filter Tube.....	86	77125	Laminin Coated Ware.....	34
65115	Filter Tube.....	86	78025	Collagen Type IV Coated Ware.....	35
65205	Filter Tube.....	86	78075	Collagen Type IV Coated Ware.....	35
65215	Filter Tube.....	86	79075	Fibronectin Coated Ware.....	36
66105	Filter Tube.....	86	79125	Fibronectin Coated Ware.....	36
66115	Filter Tube.....	86	8		
66205	Filter Tube.....	86	80010	Omni Box.....	150
66215	Filter Tube.....	86	80025	Cryo Box.....	68
66900	Spin Column.....	93	80081	Cryo Box.....	68
66901	Spin Column.....	93	80096	PCR Tube Rack.....	133
66902	Spin Column.....	93	80100	Storage Box.....	134
7			80116	Conical Tube Storage Box.....	134
70012	Cell Culture Flask.....	19	80136	Conical Tube Storage Box.....	134
700225	Cell Culture Flask.....	19	80181	Cryo Box.....	68
70025	Cell Culture Flask.....	19	80216	25 ml Tube Storage Box.....	135
70075	Cell Culture Flask.....	19	80236	5 ml Tube Storage Box.....	135
70112	Cell Culture Flask.....	19	80281	Cryo Box.....	68
701225	Cell Culture Flask.....	19	81081	Storage Box.....	134
70125	Cell Culture Flask.....	19	81100	Storage Box.....	134
70175	Cell Culture Flask.....	19	82101	MOUZIP®.....	150
70212	Cell Culture Flask.....	19	84100	Storage Box.....	134
702225	Cell Culture Flask.....	19	9		
70225	Cell Culture Flask.....	19	90001	Loop & Needle.....	106
70275	Cell Culture Flask.....	19	90010	Loop & Needle.....	106
70312	Cell Culture Flask.....	19	90020	Cell Scraper.....	74
703225	Cell Culture Flask.....	19	90021	Cell Scraper.....	74
70325	Cell Culture Flask.....	19	90030	Cell Scraper.....	74
70375	Cell Culture Flask.....	19	90031	Cell Scraper.....	74
710025	Matrix™ Coated Ware.....	37	90032	Cell Scraper.....	74
711025	SPL3D™ 3D Cell Floater.....	48	90040	Cell Lifter.....	74
711075	SPL3D™ 3D Cell Floater.....	48	90050	Spreaders.....	106
71175	Cell Culture Flask.....	19	90060	Disposable Tweezers.....	154
72175	Cell Culture Flask.....	19	90061	Disposable Tweezers.....	154
73000	Erlenmeyer Flask.....	27, 104	90070	Cloning Cylinder.....	75
73002	Erlenmeyer Flask.....	27, 104	90071	Cloning Cylinder.....	75
73003	Erlenmeyer Flask.....	27, 104	90072	Cloning Cylinder.....	75

90100	Grid Sticker.....	107	95001	Serological Pipette	110
91001	Serological Pipette	110	95002	Serological Pipette	110
91002	Serological Pipette	110	95005	Serological Pipette	110
91005	Serological Pipette	110	95010	Serological Pipette	110
91010	Serological Pipette	110	95025	Serological Pipette	110
91025	Serological Pipette	110	95050	Serological Pipette	110
91050	Serological Pipette	110	95205	Serological Pipette	110
91110	Serological Pipette	110	95210	Serological Pipette	110
911107	Multi Insert Dish.....	52	95225	Serological Pipette	110
911117	Multi Insert Dish.....	52	95250	Serological Pipette	110
911604	Spheroid Forming Unit	50	96000	SPL SEAL™	96
911605	Multi Insert Dish.....	52	96001	Label Protection Tape	152
911606	Multi Insert Dish.....	52	96002	Label Protection Tape	152
911607	Multi Insert Dish.....	52	96003	Label Protection Tape	152
911615	Multi Insert Dish.....	52	96004	SPL SEAL™ Pressure-sensitive tape	96
911617	Multi Insert Dish.....	52	96005	SPL SEAL™ Aluminum Tape.....	97
911625	Multi Insert Dish.....	52	96006	Sealing Mat	147
911627	Multi Insert Dish.....	52	96007	Sealing Mat	147
92000	Micropipette Tip.....	112	97000	Blender Bag	115
92001	Micropipette Tip.....	112	97001	Blender Bag.....	115
92002	Micropipette Tip.....	112	97002	Blender Bag.....	115
92003	Micropipette Tip.....	112	97003	Dialysis Chamber	88
92004	Micropipette Tip.....	112	97007	Dialysis Chamber	88
92010	Micropipette Tip.....	112	97014	Dialysis Chamber	88
92011	Micropipette Tip.....	112	97099	Dialysis Chamber	88
92012	Micropipette Tip.....	112	97103	Dialysis Chamber	88
92013	Micropipette Tip.....	112	97107	Dialysis Chamber	88
92014	Micropipette Tip.....	112	97114	Dialysis Chamber	88
92020	Micropipette Tip.....	112	98000	Biohazard Bag.....	155
92021	Micropipette Tip.....	112	98001	Biohazard Bag.....	155
92022	Micropipette Tip.....	112	98002	Biohazard Bag.....	155
92023	Micropipette Tip.....	112	98101	Silicone Tubing	156
92024	Micropipette Tip.....	112	98102	Silicone Tubing	156
92108	Q-suction 8-Tip.....	114	98103	Silicone Tubing	156
92200	Micropipette Tip.....	112	98104	Silicone Tubing	156
92201	Micropipette Tip.....	112	98105	Silicone Tubing	156
92202	Micropipette Tip.....	112	98106	Silicone Tubing	156
92203	Micropipette Tip.....	112	98107	Silicone Tubing	156
92204	Micropipette Tip.....	112	98108	Silicone Tubing	156
92208	Q-suction 8-Tip.....	114	98109	Silicone Tubing	156
92308	Q-suction 8-Tip.....	114	98110	Silicone Tubing	156
93001	Serological Pipette	110	98112	Silicone Tubing	156
93002	Serological Pipette	110	98115	Silicone Tubing	156
93005	Serological Pipette	110	98201	Silicone Tubing	156
93010	Serological Pipette	110	98202	Silicone Tubing	156
93025	Serological Pipette	110	98203	Silicone Tubing	156
93040	Cell Strainer.....	72	98204	Silicone Tubing	156
93050	Serological Pipette	110	98205	Silicone Tubing	156
93070	Cell Strainer.....	72	98206	Silicone Tubing	156
93100	Cell Strainer.....	72	98207	Silicone Tubing	156
94001	Aspiration Pipette	112	98208	Silicone Tubing	156
94002	Aspiration Pipette	112	98209	Silicone Tubing	156
94005	Aspiration Pipette	112	98210	Silicone Tubing	156
94010	Aspiration Pipette	112	98212	Silicone Tubing	156
94020	Multi C-Strainer	73	98215	Silicone Tubing	156
94030	Multi C-Strainer	73	98303	Silicone Tubing	156
94040	Multi C-Strainer	73	98304	Silicone Tubing	156
94070	Multi C-Strainer	73	98305	Silicone Tubing	156
94100	Multi C-Strainer	73	98306	Silicone Tubing	156

98307	Silicone Tubing	156
98308	Silicone Tubing	156
98310	Silicone Tubing	156
99000	Antibiotic Disc.....	107
99001	Port Cap	145
99005	Spheroid Forming Gel	51

A

BA400900	Vacuum Needle Holder	175
BA410120	Specimen Cup & Bottle	170
BA50212	Transport Tube.....	176
G9100	Glove (Safe Guard)	153
G9110	Glove (Safe Guard)	153
G9120	Glove (Safe Guard)	153
G9130	Glove (Safe Guard)	153
G9200	Glove (Safe Guard)	153
G9210	Glove (Safe Guard)	153
G9220	Glove (Safe Guard)	153
G9230	Glove (Safe Guard)	153

Manufacturing Facilities



Naejin-ro Plant I



R&D Center



A Plant :
Dedicated To Cell Culture Products



B Plant :
Dedicated To Injection Blow Bottles



C Plant :
Dedicated To Conical Tubes



E Plant :
E-Beam Irradiation Facility



P Plant :
Dedicated To Serological Pipettes



F Plant :
Dedicated To Cell Culture Flasks



K Plant :
For Key-Products in Life Science



Access to Quick Video tour of
SPL life Sciences site



Point of Contact



SPL Lifesciences Headquarters

**SPL Lifesciences Headquarters
R&D Center, A Plant, B Plant, C Plant**
48, Geumgang-ro 2047beon-gil,
Naecheon-myeon, Pocheon-si,
Gyeonggi-do, Korea

**Naejin-ro Plant I
E Plant, P Plant**
266, Naejin-ro, Naecheon-myeon,
Pocheon-si, Gyeonggi-do, Korea

**Naejin-ro Plant II
F Plant, K Plant**
310-16, Naejin-ro, Naecheon-myeon,
Pocheon-si, Gyeonggi-do, Korea

For more information about SPL products,
please visit our website:

KOREAN



ispl.co.kr

ENGLISH



spllifesciences.com

**To place an order,
contact local distributor or**
Tel +82 31)533-4800
Fax +82 31)533-1430
Email business@ispl.co.kr

**For technical assistance,
contact SPL R&D Center at:**
Tel +82 31)533-4800
Fax +82 31)533-1430
Email spl@ispl.co.kr

**Want to learn more about
products of SPL Life Sciences
used in Specialized bioprocess?**



Check out the
SPL Life Sciences website
for more information.
spllifesciences.com



SPL Life Sciences Co., Ltd. spllifesciences.com
26, Geumgang-ro 2047beon-gil, Naechon-myeon, Pocheon-si, Gyeonggi-do 11192, Republic of Korea
Tel. +82 31)533-4800 Fax. +82 31)533-1430